



TSWELOPELE
LOCAL MUNICIPALITY
A MUNICIPALITY IN PROGRESS

Name of the Bidder.....

CSD

Number.....

Address.....

.....

.....

Contact

Number.....

E-mail

Address.....

Closing date: 20 February 2024

Please initial here (witnesses included)

CONTENTS

1.ADVERT CALLING FOR SUBMISSION OF BIDS	3
2. RERTURNABLE DOCUMENTS.....	4-5
3. BID EVALUATION CRITERIA.....	6-7
4. SCOPE AND PRICING	13-95
5. FINANCIAL OFFER AND SPECIFICATIONS.....	12
6. SCOPE AND PRICING	13-94
7. AUTHORITY TO SIGN A BID	37
8. FORM OF OFFER AND ACCEPTANCE.....	40
9. MUNICIPAL BIDDING DOCUMENT (MBD) 1.....	86
10.MUNICIPALBIDDINGDOCUMEN (MBD) 2.....	91
11.MUNICIPAL BIDDING DOCUMENT (MBD) 4.....	92
12.MUNICIPAL BIDDING DOCUMENT (MBD) 6.1	101
13.MUNICIPAL BIDDING DOCUMENT (MBD) 8.....	111
14.MUNICIPAL BIDDING DOCUMENT (MBD) 9.....	115
15. DECLARATION BY TENDERER	11

Please initial here (witnesses included)

1. ADVERT CALLING FOR SUBMISSION OF BIDS

TENDER NUMBER – SCM/TSW18/2023-2024: REPAIRS AND MAINTENANCE OF SEWERAGE PUMPS WITHIN TSWELOPELE LOCAL MUNICIPALITY FOR THE PERIOD ENDING 30 JUNE 2026.

Tswelopele Local Municipality hereby invites suitably qualified service providers Repairs and Maintenance of sewerage pumps within Tswelopele Local Municipality for period ending 30 June 2026.

Bids marked for the attention of the Municipal Manager must be submitted in a sealed envelope marked “**Tender Number– “SCM/TSW18/2023-2024: REPAIRS AND MAINTENANCE OF SEWERAGE PUMPS WITHIN TSWELOPELE LOCAL MUNICIPALITY FOR THE PERIOD ENDING 30 JUNE 2026”**” must be deposited in the tender box located at Tswelopele Local Municipality no later 20 February 2024, 12H00 at the following physical address:

Tswelopele Local Municipality Offices; No. 1 Bosman Street; Bultfontein; 9670.

Tender documents are available from etender portal www.etenders.gov.za from the 01 February 2024.

The tenders will be evaluated and adjudicated in line with the approved Supply Chain Management Policy of Tswelopele Local Municipality using 80/20 preference point system in accordance with the Preferential Procurement Regulations, 2022.

Tenders will also be evaluated Stage 1 – Returnables, stage – 2 Functionality, Stage 3 – Price and Specified Goals (80/20).Black, women, Disability and youth Owned.

MR SS Rabanye
Acting Municipal Manager

2. RETURNABLE DOCUMENTS

The following particulars must be furnished /attached failure to do so WILL result in your bid being disqualified		
No.	Details	Tick(x)
1.	Name of bidder (MBD1) as it appears on the company registration document	
2.	Physical address (MBD1) of where the business is situated	
3.	Postal address (MBD1) of where the business receives its mails	
4.	Contact numbers (telephone, fax & cellular phone no. (MBD1))	
5.	Certificate of Payment of Municipal Accounts Evidence that municipal rates and taxes are not in arrears for more than three months for both the company and its registered Directors (this should be for any registered office, not necessarily within Tswelopele Local Municipality, in case of lease agreement should be accompanied by the service account of the lessor (No exceptions).	
6.	Valid tax clearance certificate or SARS PIN	
7.	Certificate of registration as a Bank in terms of the Banks Act, No 94 of 1990	
8.	ID Copies of the directors of the business	
9.	Completed and signed MBD forms (ALL MBD forms in the tender)	
10.	Letter of intent for the test bay	

Please initial here (witnesses included)

11.	Proof of banking not older than 3 months	
12.	Certificate of authority of signatory not older than 3 months	
13.	Valid BBEE certificate issued by SANAS accredited agencies or issued by registered auditors accredited by IRBA or certified Sworn Affidavits .	
14.	Completed and signed form of offer	
15.	Signed and completed addenda to the tender (if applicable)	
16.	Proof that the supplier is registered on the Centralised Suppliers Database (CSD)	

3. BID EVALUATION CRITERIA

Data
Telephonic, telegraphic, telex, facsimile or e-mailed tender offers will not be accepted.
The closing time for submission of tender offers is: 12H00 on the 20 February 2024
The tender offer validity period is 90 days commencing from the closing date of tender.
Access must be provided for the following inspections, tests and analysis: General site inspections and any other inspections deemed necessary by the Employer's agent and Employer.
All Functionality letters will be put through a verification process

Please initial here (witnesses included)

The tenderer is required to submit with his tender

(1) an original valid Tax Clearance Certificate issued by the South African Revenue Services; and Pin Confirmation letter from SARS

(2) copy of CSD report.

and

(3) documents as stipulated at returnable documents.

The time and location for opening of the tender offers are

Time: 12H00 (20 February 2024)

Location: Tswelopele Local Municipality, 01 Bosman Street, Civic Centre, Bultfontein, 9670 @12h00 pm.

all the documents/ returnables submitted along with the tender documents will be evaluated and verified with relevant institutions, any fictitious documents will be disregarded during the evaluation processes and if documents are regarded as materially been fictitious will be subject to relevant authorities for fraud and corruption

Please initial here (witnesses included)

The preference procedure for evaluation of responsive tender offers shall be the 80/20-point preference system, in full compliance with Tswelopele Local Municipality Preferential Procurement Policy, included as Annex P to the Tender Data

Add the following:

BID EVALUATION CRITERIA

The bids will be evaluated in three (3) stages, namely:

- Stage 1: Responsiveness
- Stage 2: Functionality
- Stage 3: Financial Offer and Preference Evaluation

STAGE 1 – RESPONSIVENESS

Failure of the bidder to submit the following will result in immediate disqualification:

- A bidders must be registered on the Central Supplier Database (CSD) of the National Treasury. Failure to submit CSD Registration Documentation will lead to disqualification.
- Tax compliance on CSD status.
- .

Please initial here (witnesses included)

- Evidence that municipal rates and taxes are not in arrears for more than three months for both the company and its registered Directors (this should be for any registered office, not necessarily within Tswelopele Local Municipality, in case of lease agreement should be accompanied by the service account of the lessor (No exceptions).
- Municipal rates of lessor to be attached.
- No bid will be considered from the persons in the Service/Employment of the State/Government/State Owned Entities.
- Bids must be valid for a minimum period of 90 days
- Bidder must own a workshop and test bay.

STAGE 2 – FUNCTIONALITY

The following documents will be required to test for functionality.

A minimum of 70 points must be attained to be responsive on functionality. The table below indicates the criteria for functionality.

The following functionality criteria will be applied:

	The minimum qualifying score for functionality is 70 points to be further evaluated	
ITEM	CRITERIA	WEIGHT
A	Bidder must provide a list of no less than (3) appointment letters from local authorities that they provide repairs and maintenance of Sewer and Water Pumps.	30
	1. 4> x Appointment letters	30
	2. 2-4x Appointment Letters	20
	3. 1-2 x Appointment Letters	10
B.	The bidder must provide their emergency recovery plan with regard to repairs (in-case of pump burst)	10

Please initial here (witnesses included)

	-Copy of disaster recovery plan attached	10
	- Copy disaster recovery plan not attached	0
C.	<u>References to customer satisfaction rating on the service provided on similar environment (only from clients indicated above)</u>	15
	1. 3 and above Clients satisfaction letter	15
	2. 2-3 Clients satisfaction letter	10
	3. 1-2 Clients satisfaction letter	5
D	Distance for Tenderers test bay and workshop or letter of intent to hire test bay from the Municipality(To be inspected)	30
	1. 20km to 100km from Bultfontein and Hoopstad	30
	2. 100km to 200km from Bultfontein and Hoopstad	20
	3. 200km and above from Bultfontein and Hoopstad	10
E	Financial Capacity (Bank rating)	15
	1. Code C	15
	2. Code D	10
	3. Code E	5
TOTAL POINTS		100

SCHEDULE OF EQUIPMENTS REQUIRED FOR THE CONTRACT

The Bidder shall state below what Equipment will be available for the work should they be awarded the Contract.

DESCRIPTION	SIZE/DESCRIPTION	QUANT
1. Call out Vehicles [ownership papers for all vehicles must be attached]		

Please initial here (witnesses included)

2. Other: Specify		

FORM 2.1.2 SIZE OF ENTERPRISE AND CURRENT WORKLOAD

[please attach Annual report for the Previous financial year]

- a) Total Turnover in the previous financial year?
R _____
- b) Estimated turnover for current financial year? R _____

Physical facilities: Provide information on Company offices/Premises

Description	Address	Area (m ²)

List current contracts and obligations [maximum]:

Description	Location	Value (R)	Start date	Expected completion date

Please initial here (witnesses included)

FORM 2.1.3 PROPOSED KEY PERSONNEL

The Bidder shall list below the key personnel (including first nominee and the second choice alternate), whom he proposes to employ on the project should his Bid be accepted, both at his headquarters and on the Site, to direct and for the execution of the work, together with their qualifications, experience, positions held and their nationalities.

DESIGNATION	INITIALS & SURNAME	HIGHEST QUALIFICATION	EXPERIENCE [NO OF YEARS]
HEADQUARTERS Partner/director			
Project Manager (s)			

FORM 2.1.4 SCHEDULE OF PREVIOUS WORK CARRIED OUT BY BIDDER

Please initial here (witnesses included)

Provide the following information on **relevant previous experience [Business Machines]**. Indicate comparable projects of similar or larger size. This information is material to the award of the Contract.

Give names and telephone numbers and e-mail address per reference. Please provide latest contact details.

CLIENT NAME AND PLACE WHERE PROJECT WAS IMPLEMENTED	TEL NO, FAX NO, EMAIL	DESCRIPTION OF WORK	CONTRACT VALUE (R)	CONTRACT PERIOD
	<hr/> <hr/> <hr/>			
	<hr/> <hr/> <hr/>			
	<hr/> <hr/> <hr/>			

Please initial here (witnesses included)

STAGE 3: FINANCIAL OFFER AND PREFERENCE EVALUATION

1. Price: 80 Points (Maximum)

Points scored for price (maximum 80 points) using the following formula:

$$◆◆◆◆ = 80 (1 - Pt - Pmin / Pmin)$$

Where,

Ps = Points scored for comparative price of bid/offer under consideration
Pt = Comparative price of bid/offer under consideration

Pmin = Comparative price of lowest acceptable bid/offer

Points scored must be rounded off to the nearest 2 decimal places.

2. Preference: 20 Points (Maximum) (Specific Goals)

SPECIFIC GOALS NUMBER OF POINTS FOR DOCUMENTATION PREFERENCE REQUIRED FROM THE BIDDER TO VALIDATE THEIR CLAIM FOR POINTS

80/20 90/10

Black owned

OR

Women owned

OR

Youth

OR

People with disability

Certificate or Sworn Affidavit and Certified Copy of the ID or CIPC Documentations and Medical certificate in order to claim specified goals points.

Please initial here (witnesses included)

4. SCOPE AND PRICING

GORMAN RUPP: T3 A35-B /FM 5.5KW MOTOR 380V RPM 1460		JOB NO	
QUOTATION NO:			
ORDER NO:			
INVOICE NO:			
INVOICE DATE:			
SPARES REQUIRED	QUANTITY	COSTING	
Mechanical Seal	1		
Shaft Sleeve	1		
Oil Seal	1		
Outboard Bearing 6308 2RSC3	1		
Inboard Ball Bearing 3308 ANRC3	1		
Seal Plate Gasket	1		
Bearing Cap Gasket	1		
Impeller Capscrew	1		
Impeller Washer	1		
Impeller Adj Shim Set	1		
Adj Shim Set	1		
Rotating Assembly O-Ring	1		
Sight Gauge	1		
Shaft Key	1		
Bearing Retaining Ring	1		
Impeller	1		
Wear Plate	1		
Shaft	1		
Flap Valve	1		
Seal Plate	1		
Oil	1		
MACHINE			
Paint per litre	1		
Cleaning solvents per litre	1		
Sandblast	1		
Test	1		

Please initial here (witnesses included)

Labour – Strip				1			
Labour – Assemble				1			
				Total Cost			
				Sub Total			
DATE COMPLETE				Labour hours			
SIGNATURE				Quoted Price			

MOTOR REPAIRS: For All Motors		JOB NO
QUOTATION NO:		
ORDER NO:		
INVOICE NO:		
INVOICE DATE:		

SPARES REQUIRED	QUANTITY	COSTING
Bearings	1	
Mechanical Seal	1	
Gland Packing	1	
Rotor Repairs	1	
Fan	1	
Wash & Bake Starter	1	
Rewind Starter	1	
Terminal Box Complete	1	
Cowl	1	
Oil Seat	1	
Drill Tap	1	
Sandblasting	1	
Test	1	
Cleaning	1	
Paint	1	
Consumables	1	
Labour Strip	1	
Labour Assemble	1	
Labour on Site	1	

Please initial here (witnesses included)

				Total Cost
				Sub Total
DATE COMPLETE				Labour
SIGNATURE				Quoted Price

(1)SUBMERSIBLE PUMPS: FLYGT 3153, 380VOLT, 9KW		JOB NO	
QUOTATION NO:			
ORDER NO:			
INVOICE NO:			
INVOICE DATE:			
SPARES REQUIRED	QUANTITY	COSTING	
Casing	1		
Shaft	1		
Impeller	1		
Diffuser	1		
Shaft	1		
Wear Rings	1		
Shaft Sleeve	1		
New Motor	1		
Gland Packing	1		
Bearing Upper	1		
Bearing Lower	1		
Mechanical Seal Upper	1		
Mechanical Seal Lower	1		
Repair Shaft	1		
O-ring Kit	1		
Wash & Bake	1		
Rewind Starter	1		
Fan	1		
Cable	1		
Oil	1		
T-box, Lid and Terminal	1		

Please initial here (witnesses included)

Cowl	1			
MACHINE				
Paint per litre	1			
Cleaning solvents per litre	1			
Sandblast	1			
Test	1			
Labour – Strip	1			
Labour – Assemble	1			
Agitator	1			
				Total Cost
				Sub Total
DATE COMPLETE				Labour
SIGNATURE				Quoted Price

(2)SUBMERSIBLE PUMPS: FLYGT NP 3127,161HT 488CURVE 4.7KW 380 VOLT		JOB NO	
QUOTATION NO:			
ORDER NO:			
INVOICE NO:			
INVOICE DATE:			
SPARES REQUIRED	QUANTITY	COSTING	
Casing	1		
Shaft	1		
Impeller	1		
Diffuser	1		
Shaft	1		
Wear Rings	1		
Shaft Sleeve	1		
New Motor	1		
Gland Packing	1		
Bearing Upper	1		
Bearing Lower	1		
Mechanical Seal Upper	1		

Please initial here (witnesses included)

Mechanical Seal Lower	1			
Repair Shaft	1			
O-ring Kit	1			
Wash & Bake	1			
Rewind Starter	1			
Fan	1			
Cable	1			
Oil	1			
T-box, Lid and Terminal	1			
Cowl	1			
MACHINE				
Paint per litre	1			
Cleaning solvents per litre	1			
Sandblast	1			
Test	1			
Labour – Strip	1			
Labour – Assemble	1			
Agitator	1			
				Total Cost
				Sub Total
DATE COMPLETE				Labour
SIGNATURE				Quoted Price
(3)SUBMERSIBLE PUMPS: FLYGT NP3102,160LT 240CURVE 3.1KW 380 VOLT				JOB NO
QUOTATION NO:				
ORDER NO:				
INVOICE NO:				
INVOICE DATE:				
SPARES REQUIRED				QUANTITY
COSTING				
Casing	1			
Shaft	1			
Impeller	1			
Diffuser	1			
Shaft	1			

Please initial here (witnesses included)

Wear Rings	1			
Shaft Sleeve	1			
New Motor	1			
Gland Packing	1			
Bearing Upper	1			
Bearing Lower	1			
Mechanical Seal Upper	1			
Mechanical Seal Lower	1			
Repair Shaft	1			
O-ring Kit	1			
Wash & Bake	1			
Rewind Starter	1			
Fan	1			
Cable	1			
Oil	1			
T-box, Lid and Terminal	1			
Cowl	1			
MACHINE				
Paint per litre	1			
Cleaning solvents per litre	1			
Sandblast	1			
Test	1			
Labour – Strip	1			
Labour – Assemble	1			
Agitator	1			
			Total Cost	
			Sub Total	
DATE COMPLETE			Labour	
SIGNATURE			Quoted Price	
(4) CORNELL 3STX SELF PREIMING SEWER PUMP C/W 7.5KW MOTOR 380 VOLTS			JOB NO	
QUOTATION NO:				
ORDER NO:				
INVOICE NO:				

Please initial here (witnesses included)

INVOICE DATE:					
SPARES REQUIRED		QUANTITY	COSTING		
Casing		1			
Shaft		1			
Impeller		1			
Diffuser		1			
Shaft		1			
Wear Rings		1			
Shaft Sleeve		1			
New Motor		1			
Gland Packing		1			
Bearing Upper		1			
Bearing Lower		1			
Mechanical Seal Upper		1			
Mechanical Seal Lower		1			
Repair Shaft		1			
O-ring Kit		1			
Wash & Bake		1			
Rewind Starter		1			
Fan		1			
Cable		1			
Oil		1			
T-box, Lid and Terminal		1			
Cowl		1			
MACHINE					
Paint per litre		1			
Cleaning solvents per litre		1			
Sandblast		1			
Test		1			
Labour – Strip		1			
Labour – Assemble		1			
Agitator		1			
				Total Cost	
				Sub Total	
DATE COMPLETE				Labour	

Please initial here (witnesses included)

SIGNATURE		Quoted Price			
(5)SUBMERSIBLE PUMPS: FLYGT 380 VOLT 4.2KW			JOB NO		
QUOTATION NO:					
ORDER NO:					
INVOICE NO:					
INVOICE DATE:					
SPARES REQUIRED		QUANTITY	COSTING		
Casing		1			
Shaft		1			
Impeller		1			
Diffuser		1			
Shaft		1			
Wear Rings		1			
Shaft Sleeve		1			
New Motor		1			
Gland Packing		1			
Bearing Upper		1			
Bearing Lower		1			
Mechanical Seal Upper		1			
Mechanical Seal Lower		1			
Repair Shaft		1			
O-ring Kit		1			
Wash & Bake		1			
Rewind Starter		1			
Fan		1			
Cable		1			
Oil		1			
T-box, Lid and Terminal		1			
Cowl		1			
MACHINE					
Paint per litre		1			
Cleaning solvents per litre		1			
Sandblast		1			
Test		1			

Please initial here (witnesses included)

Labour – Strip	1				
Labour – Assemble	1				
Agitator	1				
				Total Cost	
				Sub Total	
DATE COMPLETE			Labour		
SIGNATURE			Quoted Price		
(6)SUBMERSIBLE PUMPS FLYGT C3140 380 VOLT 4.7KW:				JOB NO	
QUOTATION NO:					
ORDER NO:					
INVOICE NO:					
INVOICE DATE:					
SPARES REQUIRED	QUANTITY	COSTING			
Casing	1				
Shaft	1				
Impeller	1				
Diffuser	1				
Shaft	1				
Wear Rings	1				
Shaft Sleeve	1				
New Motor	1				
Gland Packing	1				
Bearing Upper	1				
Bearing Lower	1				
Mechanical Seal Upper	1				
Mechanical Seal Lower	1				
Repair Shaft	1				
O-ring Kit	1				
Wash & Bake	1				
Rewind Starter	1				
Fan	1				
Cable	1				
Oil	1				

Please initial here (witnesses included)

T-box, Lid and Terminal				1			
Cowl				1			
MACHINE							
Paint per litre				1			
Cleaning solvents per litre				1			
Sandblast				1			
Test				1			
Labour – Strip				1			
Labour – Assemble				1			
Agitator				1			
DATE COMPLETE							
SIGNATURE							
(7)SUBMERSIBLE PUMPS FLYGT C3127 400 VOLT 4.7KW:							
QUOTATION NO:							
ORDER NO:							
INVOICE NO:							
INVOICE DATE:							
SPARES REQUIRED							
QUANTITY							
COSTING							
Casing				1			
Shaft				1			
Impeller				1			
Diffuser				1			
Shaft				1			
Wear Rings				1			
Shaft Sleeve				1			
New Motor				1			
Gland Packing				1			
Bearing Upper				1			
Bearing Lower				1			
Mechanical Seal Upper				1			
Mechanical Seal Lower				1			

Please initial here (witnesses included)

Shaft Sleeve	1			
New Motor	1			
Gland Packing	1			
Bearing Upper	1			
Bearing Lower	1			
Mechanical Seal Upper	1			
Mechanical Seal Lower	1			
Repair Shaft	1			
O-ring Kit	1			
Wash & Bake	1			
Rewind Starter	1			
Fan	1			
Cable	1			
Oil	1			
T-box, Lid and Terminal	1			
Cowl	1			
MACHINE				
Paint per litre	1			
Cleaning solvents per litre	1			
Sandblast	1			
Test	1			
Labour – Strip	1			
Labour – Assemble	1			
Agitator	1			
				Total Cost
				Sub Total
DATE COMPLETE				Labour
SIGNATURE				Quoted Price
(9)SUBMERSIBLE PUMPS: KSB KRTK 150-315 /46UG-S 4.8KW 400 VOLT			JOB NO	
QUOTATION NO:				
ORDER NO:				
INVOICE NO:				
INVOICE DATE:				
SPARES REQUIRED		QUANTITY	COSTING	

Please initial here (witnesses included)

QUOTATION NO:				
ORDER NO:				
INVOICE NO:				
INVOICE DATE:				
SPARES REQUIRED	QUANTITY	COSTING		
Casing	1			
Shaft	1			
Impeller	1			
Diffuser	1			
Shaft	1			
Wear Rings	1			
Shaft Sleeve	1			
New Motor	1			
Gland Packing	1			
Bearing Upper	1			
Bearing Lower	1			
Mechanical Seal Upper	1			
Mechanical Seal Lower	1			
Repair Shaft	1			
O-ring Kit	1			
Wash & Bake	1			
Rewind Starter	1			
Fan	1			
Cable	1			
Oil	1			
T-box, Lid and Terminal	1			
Cowl	1			
MACHINE				
Paint per litre	1			
Cleaning solvents per litre	1			
Sandblast	1			
Test	1			
Labour – Strip	1			
Labour – Assemble	1			
Agitator	1			

Please initial here (witnesses included)

				Total Cost			
				Sub Total			
DATE COMPLETE				Labour			
SIGNATURE				Quoted Price			
(11)SUBMERSIBLE PUMPS: KSB KRTK 100-250/5454UG-S 5.50KW 400 VOLT					JOB NO		
QUOTATION NO:							
ORDER NO:							
INVOICE NO:							
INVOICE DATE:							
SPARES REQUIRED				QUANTITY	COSTING		
Casing				1			
Shaft				1			
Impeller				1			
Diffuser				1			
Shaft				1			
Wear Rings				1			
Shaft Sleeve				1			
New Motor				1			
Gland Packing				1			
Bearing Upper				1			
Bearing Lower				1			
Mechanical Seal Upper				1			
Mechanical Seal Lower				1			
Repair Shaft				1			
O-ring Kit				1			
Wash & Bake				1			
Rewind Starter				1			
Fan				1			
Cable				1			
Oil				1			
T-box, Lid and Terminal				1			
Cowl				1			
MACHINE							

Please initial here (witnesses included)

Paint per litre	1			
Cleaning solvents per litre	1			
Sandblast	1			
Test	1			
Labour – Strip	1			
Labour – Assemble	1			
Agitator	1			
				Total Cost
				Sub Total
DATE COMPLETE				Labour
SIGNATURE				Quoted Price
(12)CENTRIFUGAL PUMPS: NK80-260/107 GRUNFOS PUMP 22KW 380 VOLTS RPM 2980			JOB NO	
QUOTATION NO:				
ORDER NO:				
INVOICE NO:				
INVOICE DATE:				
SPARES REQUIRED		QUANTITY	COSTING	
Casing		1		
Shaft		1		
Impeller		1		
Diffuser		1		
Shaft		1		
Wear Rings		1		
Shaft Sleeve		1		
New Motor		1		
Gland Packing		1		
Bearing Upper		1		
Bearing Lower		1		
Mechanical Seal Upper		1		
Mechanical Seal Lower		1		
Repair Shaft		1		
O-ring Kit		1		

Please initial here (witnesses included)

Wash & Bake	1				
Rewind Starter	1				
Fan	1				
Cable	1				
Oil	1				
T-box, Lid and Terminal	1				
Cowl	1				
MACHINE					
Paint per litre	1				
Cleaning solvents per litre	1				
Sandblast	1				
Test	1				
Labour – Strip	1				
Labour – Assemble	1				
Agitator	1				
				Total Cost	
				Sub Total	
DATE COMPLETE				Labour	
SIGNATURE				Quoted Price	
(13)SUBMERSIBLE PUMPS: FLYGT 3153 400 VOLT 9KW				JOB NO	
QUOTATION NO:					
ORDER NO:					
INVOICE NO:					
INVOICE DATE:					
SPARES REQUIRED		QUANTITY	COSTING		
Casing		1			
Shaft		1			
Impeller		1			
Diffuser		1			
Shaft		1			
Wear Rings		1			
Shaft Sleeve		1			
New Motor		1			

Please initial here (witnesses included)

Shaft	1			
Impeller	1			
Diffuser	1			
Shaft	1			
Wear Rings	1			
Shaft Sleeve	1			
New Motor	1			
Gland Packing	1			
Bearing Upper	1			
Bearing Lower	1			
Mechanical Seal Upper	1			
Mechanical Seal Lower	1			
Repair Shaft	1			
O-ring Kit	1			
Wash & Bake	1			
Rewind Starter	1			
Fan	1			
Cable	1			
Oil	1			
T-box, Lid and Terminal	1			
Cowl	1			
MACHINE				
Paint per litre	1			
Cleaning solvents per litre	1			
Sandblast	1			
Test	1			
Labour – Strip	1			
Labour – Assemble	1			
Agitator	1			
			Total Cost	
			Sub Total	
DATE COMPLETE			Labour	
SIGNATURE			Quoted Price	
(15)SUBMERSIBLE PUMPS: FLIGT 2.4 KW 380V RPM 1460			JOB NO	

Please initial here (witnesses included)

QUOTATION NO:				
ORDER NO:				
INVOICE NO:				
INVOICE DATE:				
SPARES REQUIRED	QUANTITY	COSTING		
Casing	1			
Shaft	1			
Impeller	1			
Diffuser	1			
Shaft	1			
Wear Rings	1			
Shaft Sleeve	1			
New Motor	1			
Gland Packing	1			
Bearing Upper	1			
Bearing Lower	1			
Mechanical Seal Upper	1			
Mechanical Seal Lower	1			
Repair Shaft	1			
O-ring Kit	1			
Wash & Bake	1			
Rewind Starter	1			
Fan	1			
Cable	1			
Oil	1			
T-box, Lid and Terminal	1			
Cowl	1			
MACHINE				
Paint per litre	1			
Cleaning solvents per litre	1			
Sandblast	1			
Test	1			
Labour – Strip	1			
Labour – Assemble	1			
Agitator	1			

Please initial here (witnesses included)

				Total Cost			
				Sub Total			
DATE COMPLETE				Labour			
SIGNATURE				Quoted Price			
(16)SELF-PRIMING CORNELL MODEL 6NHTA-RP-F18DB C/W 75KW IE3 MOTOR 380V RPM 1460					JOB NO		
QUOTATION NO:							
ORDER NO:							
INVOICE NO:							
INVOICE DATE:							
SPARES REQUIRED				QUANTITY	COSTING		
Casing				1			
Shaft				1			
Impeller				1			
Diffuser				1			
Shaft				1			
Wear Rings				1			
Shaft Sleeve				1			
New Motor				1			
Gland Packing				1			
Bearing Upper				1			
Bearing Lower				1			
Mechanical Seal Upper				1			
Mechanical Seal Lower				1			
Repair Shaft				1			
O-ring Kit				1			
Wash & Bake				1			
Rewind Starter				1			
Fan				1			
Cable				1			
Oil				1			
T-box, Lid and Terminal				1			
Cowl				1			

Please initial here (witnesses included)

MACHINE							
Paint per litre				1			
Cleaning solvents per litre				1			
Sandblast				1			
Test				1			
Labour – Strip				1			
Labour – Assemble				1			
Agitator				1			
				Total Cost			
				Sub Total			
DATE COMPLETE				Labour			
SIGNATURE				Quoted Price			

(17)MUFFIN MONSTER JWC MODEL NO.10000-0806 C/W 2.2KW 400 VOLTS 1430 RPM			JOB NO	
QUOTATION NO:				
ORDER NO:				
INVOICE NO:				
INVOICE DATE:				
SPARES REQUIRED		QUANTITY	COSTING	
Casing		1		
Shaft		1		
Impeller		1		
Diffuser		1		
Shaft		1		
Wear Rings		1		
Shaft Sleeve		1		
New Motor		1		
Gland Packing		1		
Bearing Upper		1		
Bearing Lower		1		
Mechanical Seal Upper		1		
Mechanical Seal Lower		1		

Please initial here (witnesses included)

Repair Shaft	1			
O-ring Kit	1			
Wash & Bake	1			
Rewind Starter	1			
Fan	1			
Cable	1			
Oil	1			
T-box, Lid and Terminal	1			
Cowl	1			
MACHINE				
Paint per litre	1			
Cleaning solvents per litre	1			
Sandblast	1			
Test	1			
Labour – Strip	1			
Labour – Assemble	1			
Agitator	1			
DATE COMPLETE				
SIGNATURE				
(18)SUBMERSIBLE PUMPS: FLYGT NP312HT-488 4.7KW 400V			JOB NO	
QUOTATION NO:				
ORDER NO:				
INVOICE NO:				
INVOICE DATE:				
SPARES REQUIRED	QUANTITY	COSTING		
Casing	1			
Shaft	1			
Impeller	1			
Diffuser	1			
Shaft	1			
Wear Rings	1			

Please initial here (witnesses included)

Shaft Sleeve	1			
New Motor	1			
Gland Packing	1			
Bearing Upper	1			
Bearing Lower	1			
Mechanical Seal Upper	1			
Mechanical Seal Lower	1			
Repair Shaft	1			
O-ring Kit	1			
Wash & Bake	1			
Rewind Starter	1			
Fan	1			
Cable	1			
Oil	1			
T-box, Lid and Terminal	1			
Cowl	1			
MACHINE				
Paint per litre	1			
Cleaning solvents per litre	1			
Sandblast	1			
Test	1			
Labour – Strip	1			
Labour – Assemble	1			
Agitator	1			
			Total Cost	
			Sub Total	
DATE COMPLETE			Labour	
SIGNATURE			Quoted Price	
(19)SUBMERSIBLE PUMPS: FN HCP - F33P 2.2KW 380V			JOB NO	
QUOTATION NO:				
ORDER NO:				
INVOICE NO:				
INVOICE DATE:				

Please initial here (witnesses included)

SPARES REQUIRED	QUANTITY	COSTING			
Casing	1				
Shaft	1				
Impeller	1				
Diffuser	1				
Shaft	1				
Wear Rings	1				
Shaft Sleeve	1				
New Motor	1				
Gland Packing	1				
Bearing Upper	1				
Bearing Lower	1				
Mechanical Seal Upper	1				
Mechanical Seal Lower	1				
Repair Shaft	1				
O-ring Kit	1				
Wash & Bake	1				
Rewind Starter	1				
Fan	1				
Cable	1				
Oil	1				
T-box, Lid and Terminal	1				
Cowl	1				
MACHINE					
Paint per litre	1				
Cleaning solvents per litre	1				
Sandblast	1				
Test	1				
Labour – Strip	1				
Labour – Assemble	1				
Agitator	1				
				Total Cost	
				Sub Total	
DATE COMPLETE				Labour	
SIGNATURE				Quoted Price	

Please initial here (witnesses included)

(20)SUBMERSIBLE PUMPS: NP3135HT - 455 - 9KW 400 VOLT		JOB NO	
QUOTATION NO:			
ORDER NO:			
INVOICE NO:			
INVOICE DATE:			
SPARES REQUIRED	QUANTITY	COSTING	
Casing	1		
Shaft	1		
Impeller	1		
Diffuser	1		
Shaft	1		
Wear Rings	1		
Shaft Sleeve	1		
New Motor	1		
Gland Packing	1		
Bearing Upper	1		
Bearing Lower	1		
Mechanical Seal Upper	1		
Mechanical Seal Lower	1		
Repair Shaft	1		
O-ring Kit	1		
Wash & Bake	1		
Rewind Starter	1		
Fan	1		
Cable	1		
Oil	1		
T-box, Lid and Terminal	1		
Cowl	1		
MACHINE			
Paint per litre	1		
Cleaning solvents per litre	1		
Sandblast	1		
Test	1		
Labour – Strip	1		

Please initial here (witnesses included)

Labour – Assemble	1			
Agitator	1			
			Total Cost	
			Sub Total	
DATE COMPLETE			Labour	
SIGNATURE			Quoted Price	
(21)CENTIFUGAL PUMPS: KSB ETA NORM 150-125-250 C/W 18.5KW 400 VOLTS 1470 RPM			JOB NO	
QUOTATION NO:				
ORDER NO:				
INVOICE NO:				
INVOICE DATE:				
SPARES REQUIRED		QUANTITY	COSTING	
Casing		1		
Shaft		1		
Impeller		1		
Diffuser		1		
Shaft		1		
Wear Rings		1		
Shaft Sleeve		1		
New Motor		1		
Gland Packing		1		
Bearing Upper		1		
Bearing Lower		1		
Mechanical Seal Upper		1		
Mechanical Seal Lower		1		
Repair Shaft		1		
O-ring Kit		1		
Wash & Bake		1		
Rewind Starter		1		
Fan		1		
Cable		1		
Oil		1		

Please initial here (witnesses included)

T-box, Lid and Terminal	1			
Cowl	1			
MACHINE				
Paint per litre	1			
Cleaning solvents per litre	1			
Sandblast	1			
Test	1			
Labour – Strip	1			
Labour – Assemble	1			
Agitator	1			
			Total Cost	
			Sub Total	
DATE COMPLETE			Labour	
SIGNATURE			Quoted Price	
(1)CENTRIFUGAL PUMP: RECYCLE PUMPS - AFP 3KW - SHOSALOWE			JOB NO	
QUOTATION NO:				
ORDER NO:				
INVOICE NO:				
INVOICE DATE:				
SPARES REQUIRED		QUANTITY	COSTING	
Casing		1		
Shaft		1		
Impeller		1		
Diffuser		1		
Wear Rings		1		
Shaft Sleeve		1		
New Motor		1		
Gland Packing		1		
Bearing Upper		1		
Bearing Lower		1		
Mechanical Seal Upper		1		
Mechanical Seal Lower		1		
Repair Shaft		1		

Please initial here (witnesses included)

O-ring Kit	1			
Wash & Bake	1			
Rewind Starter	1			
Fan	1			
Cable	1			
Oil	1			
T-box, Lid, and terminal	1			
Cowl	1			
MACHINE				
Paint per litre	1			
Cleaning solvents per litre	1			
Sandblast	1			
Test	1			
Labour – Strip	1			
Labour – Assemble	1			
			Total Cost	
			Sub Total	
DATE COMPLETE			Labour	
			Quoted	
SIGNATURE			Price	

(2)CENTRIFUGAL PUMP: SLUDGE PUMPS-GRUNDFOSS SE 1 100 100 50		JOB NO		
QUOTATION NO:				
ORDER NO:				
INVOICE NO:				
INVOICE DATE:				
SPARES REQUIRED		QUANTITY	COSTING	
Casing		1		
Shaft		1		
Impeller		1		
Diffuser		1		
Wear Rings		1		

Please initial here (witnesses included)

INVOICE DATE:				
SPARES REQUIRED		QUANTITY	COSTING	
Casing		1		
Shaft		1		
Impeller		1		
Diffuser		1		
Wear Rings		1		
Shaft Sleeve		1		
New Motor		1		
Gland Packing		1		
Bearing Upper		1		
Bearing Lower		1		
Mechanical Seal Upper		1		
Mechanical Seal Lower		1		
Repair Shaft		1		
O-ring Kit		1		
Wash & Bake		1		
Rewind Starter		1		
Fan		1		
Cable		1		
Oil		1		
T-box, Lid, and terminal		1		
Cowl		1		
MACHINE				
Paint per litre		1		
Cleaning solvents per litre		1		
Sandblast		1		
Test		1		
Labour – Strip		1		
Labour – Assemble		1		
			Total Cost	
			Sub Total	
DATE COMPLETE			Labour	

Please initial here (witnesses included)

SIGNATURE		Quoted Price			
------------------	--	---------------------	--	--	--

(4)CENTRIFUGAL PUMP: EMERGENCY RETURN PUMPS-GRUNDFOSS SE1 100 100 40		JOB NO		
QUOTATION NO:				
ORDER NO:				
INVOICE NO:				
INVOICE DATE:				
SPARES REQUIRED	QUANTITY	COSTING		
Casing	1			
Shaft	1			
Impeller	1			
Diffuser	1			
Wear Rings	1			
Shaft Sleeve	1			
New Motor	1			
Gland Packing	1			
Bearing Upper	1			
Bearing Lower	1			
Mechanical Seal Upper	1			
Mechanical Seal Lower	1			
Repair Shaft	1			
O-ring Kit	1			
Wash & Bake	1			
Rewind Starter	1			
Fan	1			
Cable	1			
Oil	1			
T-box, Lid, and terminal	1			
Cowl	1			
MACHINE				
Paint per litre	1			
Cleaning solvents per litre	1			

Please initial here (witnesses included)

Sandblast	1			
Test	1			
Labour – Strip	1			
Labour – Assemble	1			
		Total Cost		
		Sub Total		
DATE COMPLETE		Labour		
SIGNATURE		Quoted Price		
(5)CENTRIFUGAL PUMP: SUPERNATANT PUMPS - GRUNDFOSS NK 32 200 180.5			JOB NO	
QUOTATION NO:				
ORDER NO:				
INVOICE NO:				
INVOICE DATE:				
SPARES REQUIRED		QUANTITY	COSTING	
Casing	1			
Shaft	1			
Impeller	1			
Diffuser	1			
Wear Rings	1			
Shaft Sleeve	1			
New Motor	1			
Gland Packing	1			
Bearing Upper	1			
Bearing Lower	1			
Mechanical Seal Upper	1			
Mechanical Seal Lower	1			
Repair Shaft	1			
O-ring Kit	1			
Wash & Bake	1			
Rewind Starter	1			
Fan	1			
Cable	1			

Please initial here (witnesses included)

Oil	1						
T-box, Lid, and terminal	1						
Cowl	1						
MACHINE							
Paint per litre	1						
Cleaning solvents per litre	1						
Sandblast	1						
Test	1						
Labour – Strip	1						
Labour – Assemble	1						
			Total Cost				
			Sub Total				
DATE COMPLETE			Labour				
SIGNATURE			Quoted Price				
(6)CENTRIFUGAL PUMP: WASH WATER SUPPLY PUMPS-GRUNDFOSS NK 50 200 182.5							
		JOB NO					
					QUOTATION NO:		
					ORDER NO:		
INVOICE NO:							
INVOICE DATE:							
SPARES REQUIRED		QUANTITY	COSTING				
Casing		1					
Shaft		1					
Impeller		1					
Diffuser		1					
Wear Rings		1					
Shaft Sleeve		1					
New Motor		1					
Gland Packing		1					
Bearing Upper		1					
Bearing Lower		1					
Mechanical Seal Upper		1					

Please initial here (witnesses included)

ORDER NO:				
INVOICE NO:				
INVOICE DATE:				
SPARES REQUIRED	QUANTITY	COSTING		
Casing	1			
Shaft	1			
Impeller	1			
Diffuser	1			
Wear Rings	1			
Shaft Sleeve	1			
New Motor	1			
Gland Packing	1			
Bearing Upper	1			
Bearing Lower	1			
Mechanical Seal Upper	1			
Mechanical Seal Lower	1			
Repair Shaft	1			
O-ring Kit	1			
Wash & Bake	1			
Rewind Starter	1			
Fan	1			
Cable	1			
Oil	1			
T-box, Lid, and terminal	1			
Cowl	1			
MACHINE				
Paint per litre	1			
Cleaning solvents per litre	1			
Sandblast	1			
Test	1			
Labour – Strip	1			
Labour – Assemble	1			
			Total Cost	
			Sub Total	
DATE COMPLETE			Labour	

Please initial here (witnesses included)

SIGNATURE				Quoted Price			
(9)CENTRIFUGAL PUMP: DRAINAGE PUMP - GRUNDFOSS UNILIFT AP.50.50.08					JOB NO		
QUOTATION NO:							
ORDER NO:							
INVOICE NO:							
INVOICE DATE:							
SPARES REQUIRED		QUANTITY	COSTING				
Casing		1					
Shaft		1					
Impeller		1					
Diffuser		1					
Wear Rings		1					
Shaft Sleeve		1					
New Motor		1					
Gland Packing		1					
Bearing Upper		1					
Bearing Lower		1					
Mechanical Seal Upper		1					
Mechanical Seal Lower		1					
Repair Shaft		1					
O-ring Kit		1					
Wash & Bake		1					
Rewind Starter		1					
Fan		1					
Cable		1					
Oil		1					
T-box, Lid, and terminal		1					
Cowl		1					
MACHINE							
Paint per litre		1					
Cleaning solvents per litre		1					
Sandblast		1					

Please initial here (witnesses included)

Test	1			
Labour – Strip	1			
Labour – Assemble	1			
			Total Cost	
			Sub Total	
DATE COMPLETE			Labour	
SIGNATURE			Quoted Price	
(10)CENTRIFUGAL PUMP: KSB ETA NORM 150-400 C/W 75KW MOTOR/55KW MOTOR 380V RPM 1460			JOB NO	
QUOTATION NO:				
ORDER NO:				
INVOICE NO:				
INVOICE DATE:				
SPARES REQUIRED		QUANTITY	COSTING	
Casing	1			
Shaft	1			
Impeller	1			
Diffuser	1			
Wear Rings	1			
Shaft Sleeve	1			
New Motor	1			
Gland Packing	1			
Bearing Upper	1			
Bearing Lower	1			
Mechanical Seal Upper	1			
Mechanical Seal Lower	1			
Repair Shaft	1			
O-ring Kit	1			
Wash & Bake	1			
Rewind Starter	1			
Fan	1			

Please initial here (witnesses included)

Cable	1			
Oil	1			
T-box, Lid, and terminal	1			
Cowl	1			
MACHINE				
Paint per litre	1			
Cleaning solvents per litre	1			
Sandblast	1			
Test	1			
Labour – Strip	1			
Labour – Assemble	1			
				Total Cost
				Sub Total
DATE COMPLETE				Labour
SIGNATURE				Quoted Price
(11)CENTRIFUGAL PUMP: FPS 100-250 110KW MOTOR 380V RPM 2980				JOB NO
QUOTATION NO:				
ORDER NO:				
INVOICE NO:				
INVOICE DATE:				
SPARES REQUIRED	QUANTITY	COSTING		
Casing	1			
Shaft	1			
Impeller	1			
Diffuser	1			
Wear Rings	1			
Shaft Sleeve	1			
New Motor	1			
Gland Packing	1			
Bearing Upper	1			
Bearing Lower	1			
Mechanical Seal Upper	1			

Please initial here (witnesses included)

Impeller	1				
Diffuser	1				
Wear Rings	1				
Shaft Sleeve	1				
New Motor	1				
Gland Packing	1				
Bearing Upper	1				
Bearing Lower	1				
Mechanical Seal Upper	1				
Mechanical Seal Lower	1				
Repair Shaft	1				
O-ring Kit	1				
Wash & Bake	1				
Rewind Starter	1				
Fan	1				
Cable	1				
Oil	1				
T-box, Lid, and terminal	1				
Cowl	1				
MACHINE					
Paint per litre	1				
Cleaning solvents per litre	1				
Sandblast	1				
Test	1				
Labour – Strip	1				
Labour – Assemble	1				
				Total Cost	
				Sub Total	
DATE COMPLETE				Labour	
SIGNATURE				Quoted Price	
(13)CENTRIFUGAL PUMP: KSB 80-200 22KW MOTOR 380V				JOB NO	
QUOTATION NO:					
ORDER NO:					

Please initial here (witnesses included)

INVOICE NO:						
INVOICE DATE:						
SPARES REQUIRED				QUANTITY	COSTING	
Casing				1		
Shaft				1		
Impeller				1		
Diffuser				1		
Wear Rings				1		
Shaft Sleeve				1		
New Motor				1		
Gland Packing				1		
Bearing Upper				1		
Bearing Lower				1		
Mechanical Seal Upper				1		
Mechanical Seal Lower				1		
Repair Shaft				1		
O-ring Kit				1		
Wash & Bake				1		
Rewind Starter				1		
Fan				1		
Cable				1		
Oil				1		
T-box, Lid, and terminal				1		
Cowl				1		
MACHINE						
Paint per litre				1		
Cleaning solvents per litre				1		
Sandblast				1		
Test				1		
Labour – Strip				1		
Labour – Assemble				1		
				Total Cost		
				Sub Total		
DATE COMPLETE				Labour		

Please initial here (witnesses included)

SIGNATURE		Quoted Price			
------------------	--	---------------------	--	--	--

(14)CENTRIFUGAL PUMP: KSB ETA NORM 100-250 PUMP C/W 132KW MOTOR 400V RPM 2980		JOB NO		
QUOTATION NO:				
ORDER NO:				
INVOICE NO:				
INVOICE DATE:				
SPARES REQUIRED	QUANTITY	COSTING		
Casing	1			
Shaft	1			
Impeller	1			
Diffuser	1			
Wear Rings	1			
Shaft Sleeve	1			
New Motor	1			
Gland Packing	1			
Bearing Upper	1			
Bearing Lower	1			
Mechanical Seal Upper	1			
Mechanical Seal Lower	1			
Repair Shaft	1			
O-ring Kit	1			
Wash & Bake	1			
Rewind Starter	1			
Fan	1			
Cable	1			
Oil	1			
T-box, Lid, and terminal	1			
Cowl	1			
MACHINE				
Paint per litre	1			
Cleaning solvents per litre	1			

Please initial here (witnesses included)

Sandblast	1			
Test	1			
Labour – Strip	1			
Labour – Assemble	1			
			Total Cost	
			Sub Total	
DATE COMPLETE			Labour	
SIGNATURE			Quoted Price	
(15)CENTRIFUGAL PUMP: GRUNDFOS NK 150-250/230 A2F1BE-SBQQE WEG 22KW MOTOR 400V			JOB NO	
QUOTATION NO:				
ORDER NO:				
INVOICE NO:				
INVOICE DATE:				
SPARES REQUIRED		QUANTITY	COSTING	
Casing		1		
Shaft		1		
Impeller		1		
Diffuser		1		
Wear Rings		1		
Shaft Sleeve		1		
New Motor		1		
Gland Packing		1		
Bearing Upper		1		
Bearing Lower		1		
Mechanical Seal Upper		1		
Mechanical Seal Lower		1		
Repair Shaft		1		
O-ring Kit		1		
Wash & Bake		1		
Rewind Starter		1		
Fan		1		

Please initial here (witnesses included)

QUOTATION NO:				
ORDER NO:				
INVOICE NO:				
INVOICE DATE:				
SPARES REQUIRED				
	QUANTITY	COSTING		
Casing	1			
Shaft	1			
Impeller	1			
Diffuser	1			
Wear Rings	1			
Shaft Sleeve	1			
New Motor	1			
Gland Packing	1			
Bearing Upper	1			
Bearing Lower	1			
Mechanical Seal Upper	1			
Mechanical Seal Lower	1			
Repair Shaft	1			
O-ring Kit	1			
Wash & Bake	1			
Rewind Starter	1			
Fan	1			
Cable	1			
Oil	1			
T-box, Lid, and terminal	1			
Cowl	1			
MACHINE				
Paint per litre	1			
Cleaning solvents per litre	1			
Sandblast	1			
Test	1			
Labour – Strip	1			
Labour – Assemble	1			

Please initial here (witnesses included)

				Total Cost			
				Sub Total			
DATE COMPLETE				Labour			
SIGNATURE				Quoted Price			

(19)CENTRIFUGAL PUMP: EAGLE PUMP EA 150-32 C/W 45KW MOTOR 380V		JOB NO	
QUOTATION NO:			
ORDER NO:			
INVOICE NO:			
INVOICE DATE:			
SPARES REQUIRED	QUANTITY	COSTING	
Casing	1		
Shaft	1		
Impeller	1		
Diffuser	1		
Wear Rings	1		
Shaft Sleeve	1		
New Motor	1		
Gland Packing	1		
Bearing Upper	1		
Bearing Lower	1		
Mechanical Seal Upper	1		
Mechanical Seal Lower	1		
Repair Shaft	1		
O-ring Kit	1		
Wash & Bake	1		
Rewind Starter	1		
Fan	1		
Cable	1		
Oil	1		
T-box, Lid, and terminal	1		
Cowl	1		
MACHINE			

Please initial here (witnesses included)

Paint per litre	1			
Cleaning solvents per litre	1			
Sandblast	1			
Test	1			
Labour – Strip	1			
Labour – Assemble	1			
		Total Cost		
		Sub Total		
DATE COMPLETE		Labour		
SIGNATURE		Quoted Price		
(20)CENTRIFUGAL PUMP: FPS 150-315 45KW MOTOR 380V RPM 1460		JOB NO		
QUOTATION NO:				
ORDER NO:				
INVOICE NO:				
INVOICE DATE:				
SPARES REQUIRED		QUANTITY	COSTING	
Casing	1			
Shaft	1			
Impeller	1			
Diffuser	1			
Wear Rings	1			
Shaft Sleeve	1			
New Motor	1			
Gland Packing	1			
Bearing Upper	1			
Bearing Lower	1			
Mechanical Seal Upper	1			
Mechanical Seal Lower	1			
Repair Shaft	1			
O-ring Kit	1			
Wash & Bake	1			

Please initial here (witnesses included)

Rewind Starter	1			
Fan	1			
Cable	1			
Oil	1			
T-box, Lid, and terminal	1			
Cowl	1			
MACHINE				
Paint per litre	1			
Cleaning solvents per litre	1			
Sandblast	1			
Test	1			
Labour – Strip	1			
Labour – Assemble	1			
			Total Cost	
			Sub Total	
DATE COMPLETE			Labour	
SIGNATURE			Quoted Price	
(21)CENTRIFUGAL PUMP: KSB ETA 150-125-315 PUMP C/W 22KW MOTOR 380V RPM 1460			JOB NO	
QUOTATION NO:				
ORDER NO:				
INVOICE NO:				
INVOICE DATE:				
SPARES REQUIRED	QUANTITY	COSTING		
Casing	1			
Shaft	1			
Impeller	1			
Diffuser	1			
Wear Rings	1			
Shaft Sleeve	1			
New Motor	1			

Please initial here (witnesses included)

(23)CENTRIFUGAL PUMP: KSB ETA 100-80-400 PUMP C/W 30KW MOTOR 380V RPM 1460		JOB NO	
QUOTATION NO:			
ORDER NO:			
INVOICE NO:			
INVOICE DATE:			
SPARES REQUIRED	QUANTITY	COSTING	
Casing	1		
Shaft	1		
Impeller	1		
Diffuser	1		
Wear Rings	1		
Shaft Sleeve	1		
New Motor	1		
Gland Packing	1		
Bearing Upper	1		
Bearing Lower	1		
Mechanical Seal Upper	1		
Mechanical Seal Lower	1		
Repair Shaft	1		
O-ring Kit	1		
Wash & Bake	1		
Rewind Starter	1		
Fan	1		
Cable	1		
Oil	1		
T-box, Lid, and terminal	1		
Cowl	1		
MACHINE			
Paint per litre	1		
Cleaning solvents per litre	1		
Sandblast	1		
Test	1		
Labour – Strip	1		
Labour – Assemble	1		

Please initial here (witnesses included)

				Total Cost			
				Sub Total			
DATE COMPLETE				Labour			
SIGNATURE				Quoted Price			

(24)CENTRIFUGAL PUMP: KSB ETA 200-150-315 PUMP C/W 45 KW MOTOR 380V RPM 1460			JOB NO	
QUOTATION NO:				
ORDER NO:				
INVOICE NO:				
INVOICE DATE:				
SPARES REQUIRED		QUANTITY	COSTING	
Casing		1		
Shaft		1		
Impeller		1		
Diffuser		1		
Wear Rings		1		
Shaft Sleeve		1		
New Motor		1		
Gland Packing		1		
Bearing Upper		1		
Bearing Lower		1		
Mechanical Seal Upper		1		
Mechanical Seal Lower		1		
Repair Shaft		1		
O-ring Kit		1		
Wash & Bake		1		
Rewind Starter		1		
Fan		1		
Cable		1		
Oil		1		

Please initial here (witnesses included)

T-box, Lid, and terminal	1			
Cowl	1			
MACHINE				
Paint per litre	1			
Cleaning solvents per litre	1			
Sandblast	1			
Test	1			
Labour – Strip	1			
Labour – Assemble	1			
			Total Cost	
			Sub Total	
DATE COMPLETE			Labour	
SIGNATURE			Quoted Price	

(25)CENTRIFUGAL PUMP: UROSTREAM 40-26 / 15KW MOTOR 380V CLOSED / COUPLE PUMP RPM		JOB NO	
QUOTATION NO:			
ORDER NO:			
INVOICE NO:			
INVOICE DATE:			
SPARES REQUIRED	QUANTITY	COSTING	
Casing	1		
Shaft	1		
Impeller	1		
Diffuser	1		
Wear Rings	1		
Shaft Sleeve	1		
New Motor	1		
Gland Packing	1		
Bearing Upper	1		
Bearing Lower	1		

Please initial here (witnesses included)

Mechanical Seal Upper	1			
Mechanical Seal Lower	1			
Repair Shaft	1			
O-ring Kit	1			
Wash & Bake	1			
Rewind Starter	1			
Fan	1			
Cable	1			
Oil	1			
T-box, Lid, and terminal	1			
Cowl	1			
MACHINE				
Paint per litre	1			
Cleaning solvents per litre	1			
Sandblast	1			
Test	1			
Labour – Strip	1			
Labour – Assemble	1			
		Total Cost		
		Sub Total		
DATE COMPLETE		Labour		
SIGNATURE		Quoted Price		
WEMCO SELF-PRIMING SEWER PUMP : WSP-8A60-8 45KW/37 MOTOR 380V RPM 1460		JOB NO		
QUOTATION NO:				
ORDER NO:				
INVOICE NO:				
INVOICE DATE:				
SPARES REQUIRED	QUANTITY	COSTING		
Casing	1			
Shaft	1			
Impeller	1			

Please initial here (witnesses included)

Diffuser	1			
Wear Rings	1			
Shaft Sleeve	1			
New Motor	1			
Gland Packing	1			
Bearing Upper	1			
Bearing Lower	1			
Mechanical Seal Upper	1			
Mechanical Seal Lower	1			
Repair Shaft	1			
O-ring Kit	1			
Wash & Bake	1			
Rewind Starter	1			
Fan	1			
Cable	1			
Oil	1			
T-box, Lid, and terminal	1			
Cowl	1			
MACHINE				
Paint per litre	1			
Cleaning solvents per litre	1			
Sandblast	1			
Test	1			
Labour – Strip	1			
Labour – Assemble	1			
			Total Cost	
			Sub Total	
DATE COMPLETE			Labour	
SIGNATURE			Quoted Price	

(1)AERATORS: SURFACE AERATORS MVT 55KW		JOB NO	
QUOTATION NO:			

Please initial here (witnesses included)

(2)AERATORS: SURFACE AERATORS MVT 45KW			JOB NO		
QUOTATION NO:					
ORDER NO:					
INVOICE NO:					
INVOICE DATE:					
SPARES REQUIRED		QUANTITY	COSTING		
Gears		1			
Shaft		1			
Wear Rings		1			
Shaft Sleeve		1			
New Motor		1			
Bearing		1			
Mechanical Seal Upper		1			
Mechanical Seal Lower		1			
Repair Shaft		1			
Wash & Bake		1			
Rewind Starter		1			
Cable		1			
Oil		1			
Cowl		1			
MACHINE					
Paint per litre		1			
Cleaning solvents per litre		1			
Sandblast		1			
Test		1			
Labour – Strip		1			
Labour – Assemble		1			
		Total Cost			

Please initial here (witnesses included)

				Sub Total			
DATE COMPLETE				Labour			
SIGNATURE				Quoted Price			

(3)AERATORS: SURFACE AERATORS MVT 37KW		JOB NO	
QUOTATION NO:			
ORDER NO:			
INVOICE NO:			
INVOICE DATE:			
SPARES REQUIRED	QUANTITY	COSTING	
Gears	1		
Shaft	1		
Wear Rings	1		
Shaft Sleeve	1		
New Motor	1		
Bearing	1		
Mechanical Seal Upper	1		
Mechanical Seal Lower	1		
Repair Shaft	1		
Wash & Bake	1		
Rewind Starter	1		
Cable	1		
Oil	1		
Cowl	1		
MACHINE			
Paint per litre	1		
Cleaning solvents per litre	1		
Sandblast	1		

Please initial here (witnesses included)

Test	1			
Labour – Strip	1			
Labour – Assemble	1			
			Total Cost	
			Sub Total	
DATE COMPLETE			Labour	
SIGNATURE			Quoted Price	

(4)AERATORS: SURFACE AERATORS MVT 22KW		JOB NO	
QUOTATION NO:			
ORDER NO:			
INVOICE NO:			
INVOICE DATE:			
SPARES REQUIRED	QUANTITY	COSTING	
Gears	1		
Shaft	1		
Wear Rings	1		
Shaft Sleeve	1		
New Motor	1		
Bearing	1		
Mechanical Seal Upper	1		
Mechanical Seal Lower	1		
Repair Shaft	1		
Wash & Bake	1		
Rewind Starter	1		

Please initial here (witnesses included)

Cable	1				
Oil	1				
Cowl	1				
MACHINE					
Paint per litre	1				
Cleaning solvents per litre	1				
Sandblast	1				
Test	1				
Labour – Strip	1				
Labour – Assemble	1				
				Total Cost	
				Sub Total	
DATE COMPLETE				Labour	
SIGNATURE				Quoted Price	

ANAEROBIC MIXERS: ANAEROBIC VERTICAL SHAFT MIXERS CBT 2,2KW		JOB NO	
QUOTATION NO:			
ORDER NO:			
INVOICE NO:			
INVOICE DATE:			
SPARES REQUIRED	QUANTITY	COSTING	
Gears	1		
Shaft	1		
Wear Rings	1		
Shaft Sleeve	1		

Please initial here (witnesses included)

New Motor	1				
Bearing	1				
Mechanical Seal Upper	1				
Mechanical Seal Lower	1				
Repair Shaft	1				
Wash & Bake	1				
Rewind Starter	1				
Cable	1				
Oil	1				
Cowl	1				
MACHINE					
Paint per litre	1				
Cleaning solvents per litre	1				
Sandblast	1				
Test	1				
Labour – Strip	1				
Labour – Assemble	1				
				Total Cost	
				Sub Total	
DATE COMPLETE				Labour	
SIGNATURE				Quoted Price	

ANAEROBIC MIXERS :ANOXIC VERTICAL SHAFT MIXERS CBT 5,5KW		JOB NO	
QUOTATION NO:			
ORDER NO:			
INVOICE NO:			

Please initial here (witnesses included)

INVOICE DATE:					
SPARES REQUIRED			QUANTITY	COSTING	
Gears			1		
Shaft			1		
Wear Rings			1		
Shaft Sleeve			1		
New Motor			1		
Bearing			1		
Mechanical Seal Upper			1		
Mechanical Seal Lower			1		
Repair Shaft			1		
Wash & Bake			1		
Rewind Starter			1		
Cable			1		
Oil			1		
Cowl			1		
MACHINE					
Paint per litre			1		
Cleaning solvents per litre			1		
Sandblast			1		
Test			1		
Labour – Strip			1		
Labour – Assemble			1		
				Total Cost	
				Sub Total	
DATE COMPLETE				Labour	
SIGNATURE				Quoted Price	



Please initial here (witnesses included)

SIGNATURE		Quoted Price			
------------------	--	---------------------	--	--	--

WILLO EMU-PORT CORE SYSTEMS

WILLO EMU-PORT Hoopstad PS 1 FG-1500 R					JOB NO	
QUOTATION NO:						
ORDER NO:						
INVOICE NO:						
INVOICE DATE:						
SPARES REQUIRED				QUANTITY	COSTING	
EMU-PORT SYSTEM				1		
				Total Cost		
				Sub Total		
DATE COMPLETE				Labour		
SIGNATURE				Quoted Price		

Please initial here (witnesses included)

Technical data
Submersible sewage pump

FA 10.65E

with motor
FK 202-4/22

Pump				
Pump type	FA 10.65E		Installation type	Einhängevorrichtung 1
Impeller Ø	max. possible	318	mm	DN100S/2RK
	standard	294	mm	Free passage
	designed	294	mm	80
	min. possible	234	mm	mm
Nominal speed	1450	1/min	Suction port	Pressure rating
Frequency	50	Hz		Rated diameter
Impeller type	Single-channel		Discharge port	Standard
Impeller construction	Closed			Pressure rating
				Rated diameter
				Standard
				EN1092-2-S
				PN10
				DN100
				EN1092-2-D
Weights				
Weight of pump end	max. 77	kg	Weight of unit	max. 215
Weight of motor	138	kg		kg
Materials				
Pump housing	EN-GJL-250		Suction ports	EN-GJL-250
Stationary wear ring	1.4470			
Impeller	EN-GJS-500-7			
Mobile wear ring	1.4470			
Motor				
Motor name	FK 202-4/22		Number of poles	4
Rated power	15	kW	Rated speed	1430
Power input with rated power				18,3
Rated voltage				400 ~3
Current input with rated power				31,1
Efficiency with rated power				82
cos phi with rated power	0,85		Rated frequency	50
cos phi with starting	0,55		Operation type wet	S1
Starting current, direct starting	125	A	Operation type dry	S1
Starting current, star-delta	41,7	A	Max. fluid temperature	60
Starting torque	164	Nm	Starts per hour max.	15
Inertia moment	0,0438	kg m ²	Degree of protection	IP 68
Sel. explosion protection			Ex-number	ATEX=- / FM=- / CSA=-
Ex-designation	ATEX=- / FM=- / CSA=-			
Motor connection cable				4x6 + 2x1,5 NSSHÖU
Duty point data				
Volume flow	33,4	l/s	Fluid	Wastewater
Head	22,9	m	Required pump NPSH	2,7
Shaft power	P ₂	10,7	kW	Speed
Pump efficiency	70,3	%		1450
Power input	P ₁	12,7	kW	Total efficiency
				$\frac{P_2 * \text{Pump efficiency}}{P_1}$
Item no.				

Please initial here (witnesses included)

Technical data

Submersible sewage pump

FA 10.65E

with motor

FK 202-4/22

Tender text

Submersible Sewage Pump as submersible, single-stage block unit in stationary, vertical installation to pump untreated sewage which doesn't attack the pump neither chemically nor mechanically. Pump with radially arranged discharge piece and axial pump intake. Service-friendly design by separated motor and pump casing. Pumping values to be guaranteed as per ISO 9906 Annex A

Submersible motor in pressure-resistant design, with internal, sealed, active circulation cooling and heat exchanger, double mechanical shaft seal in EMU block design as well as separate sealing chamber. The motor chamber and sealing chamber are filled with medical white oil.

Motor sealing at the shaft by a double, wear-resistant mechanical shaft seal independent of the direction on rotation entirely made of silicon-carbide as closed unit, in EMU sealing cartridge of stainless steel with intermediate separation chamber. Both seals are cooled and lubricated by medical white oil. The motor chamber is equipped with a terminal board. The motor is equipped with two maintenance-free ball bearings.

The upper bearing is filled with high-quality grease, the lower bearing is oil-lubricated. Possibility for retrofitting a moisture probe by means of a pencil electrode for protection against penetrating humidity. All casing parts are of cast iron.

Shaft and connecting elements are of stainless steel. The motor is suitable for continuous operation (S1) under full load in immersed and completely emerged condition.

Please initial here (witnesses included)

Performance curves
Submersible sewage pump

FA 10.65E

with motor
FK 202-4/22

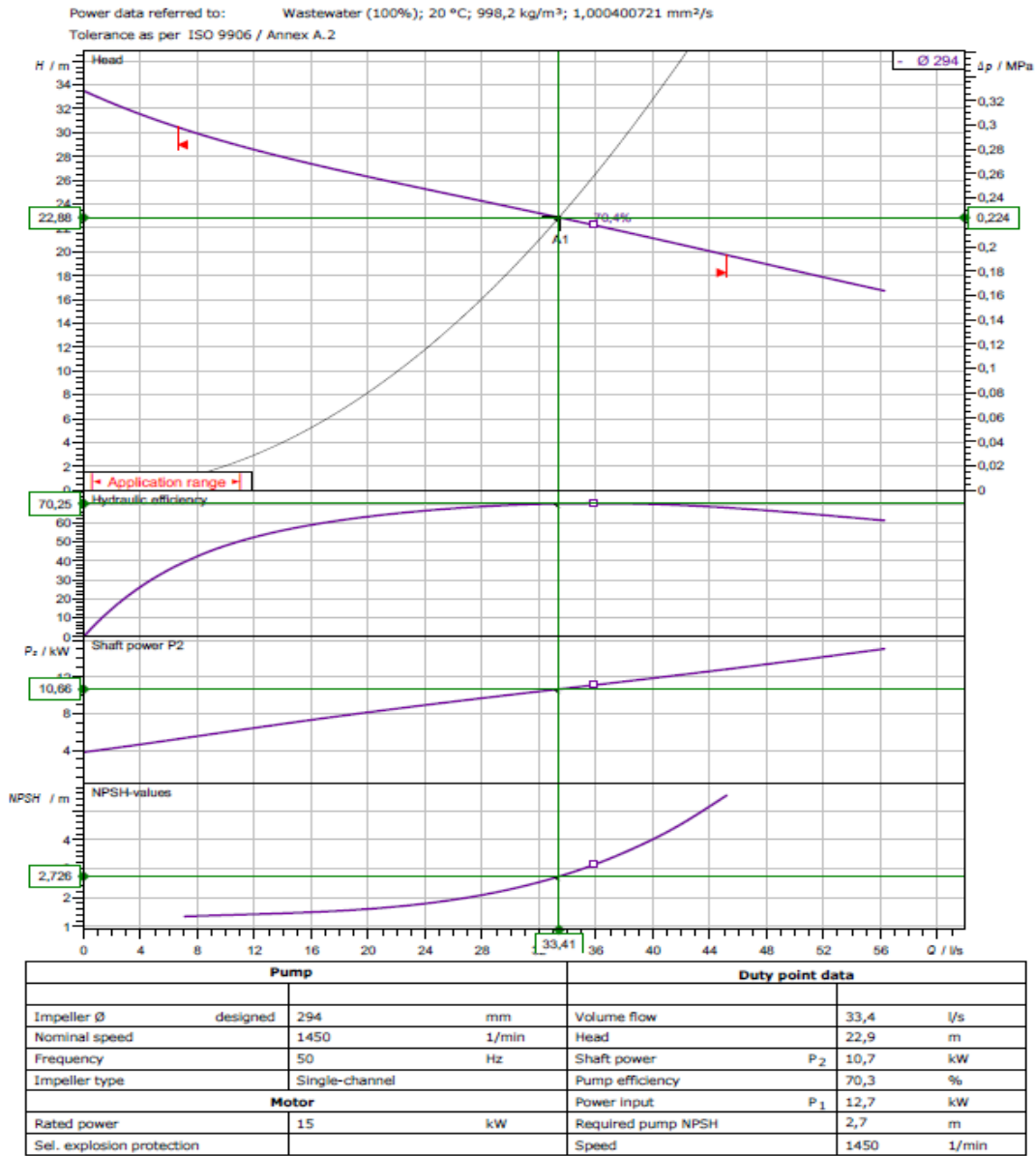

Please initial here (witnesses included)

Technical data
Submersible sewage pump

FA 10.65E

with motor
FK 202-4/22

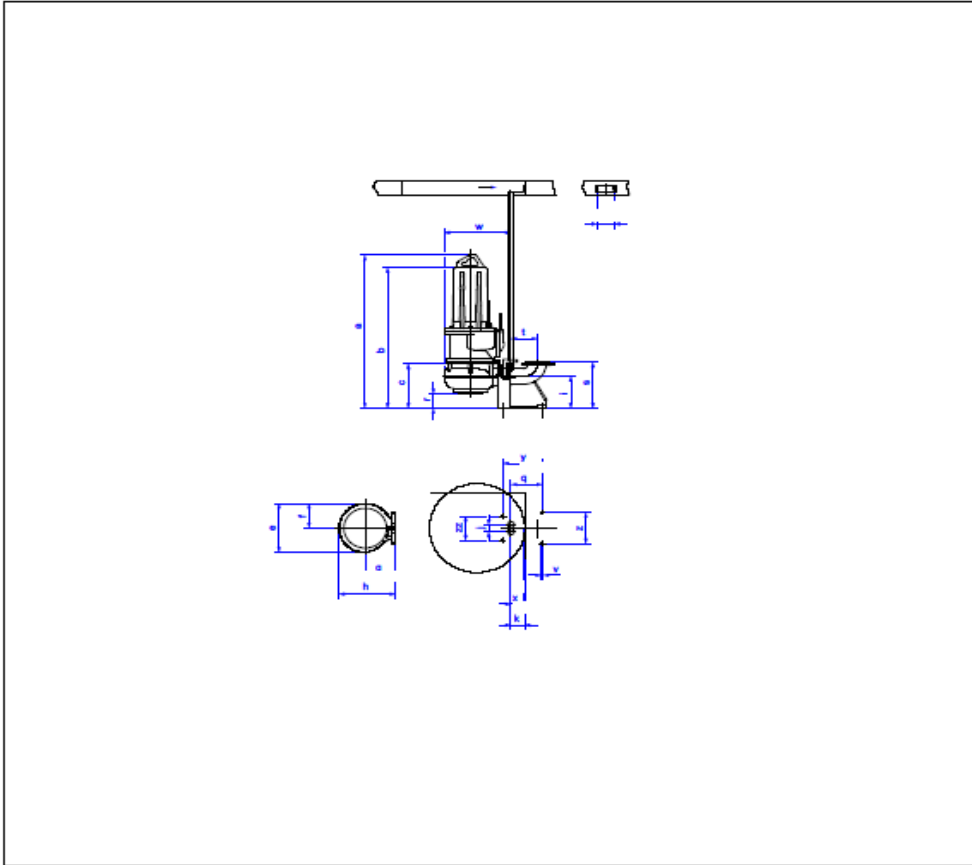

Dimensions in mm				Connections
a	1122	v	13,5	Suction port DN100 PN10
b	301	w	571	
c	301	x	90	
d	110	y	260	Discharge port DN100 PN10
k	98	z	220	
i	225	e	474	
j	50	f	258	Einhängevorrichtung 1 DN100S/2RK
q	206	g	280	
r	125	h	506	
s	325	zz	170	
t	176			

Please initial here (witnesses included)

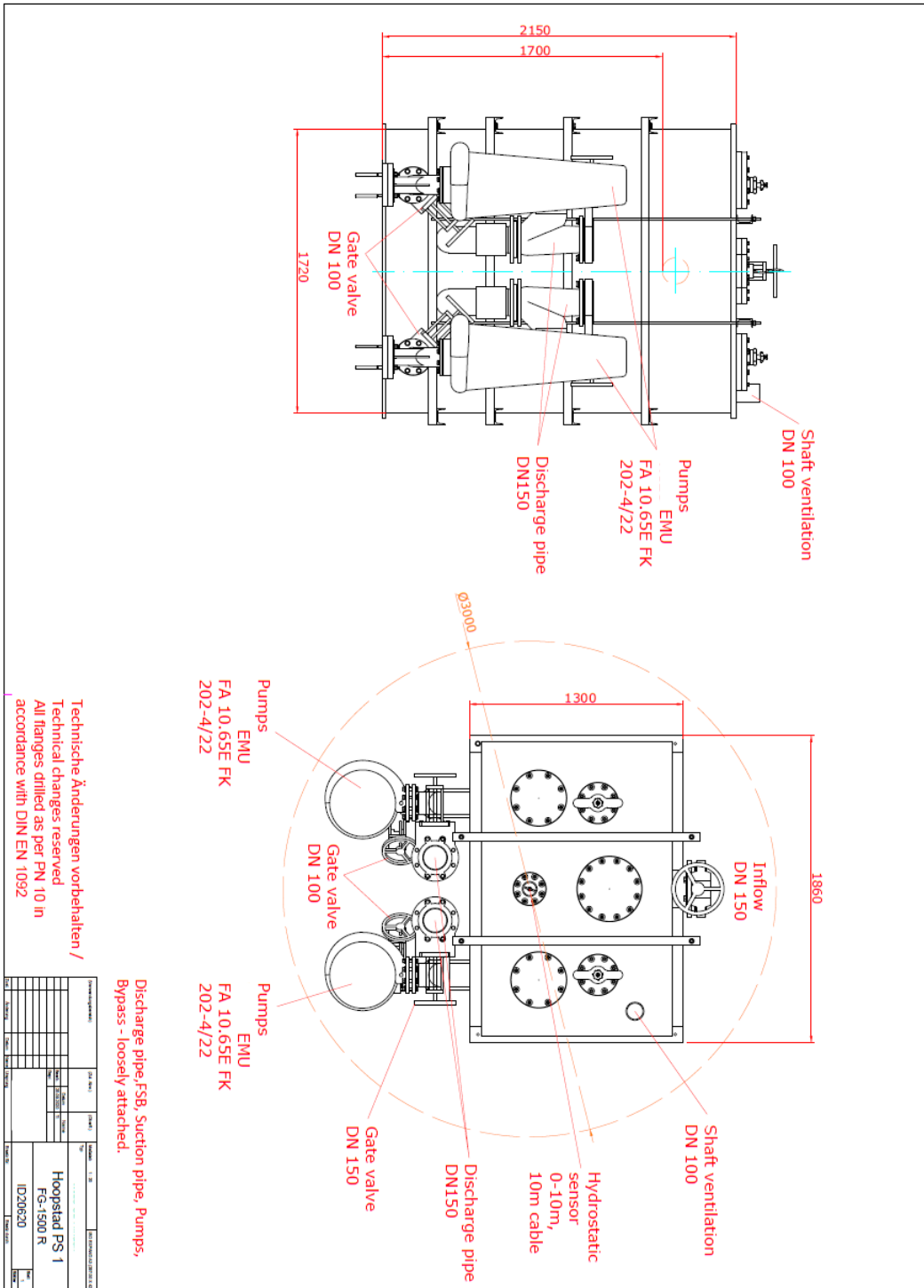

Please initial here (witnesses included)

WILLO EMU-PORT CORE 50.2-15B PS NO 02					JOB NO	
QUOTATION NO:						
ORDER NO:						
INVOICE NO:						
INVOICE DATE:						
SPARES REQUIRED				QUANTITY	COSTING	
EMU-PORT SYSTEM				1		
				Total Cost		
				Sub Total		
DATE COMPLETE				Labour		
SIGNATURE				Quoted Price		

Please initial here (witnesses included)

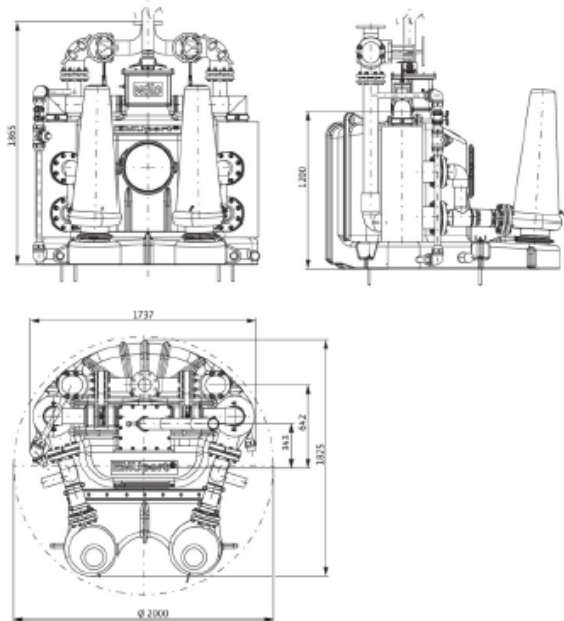
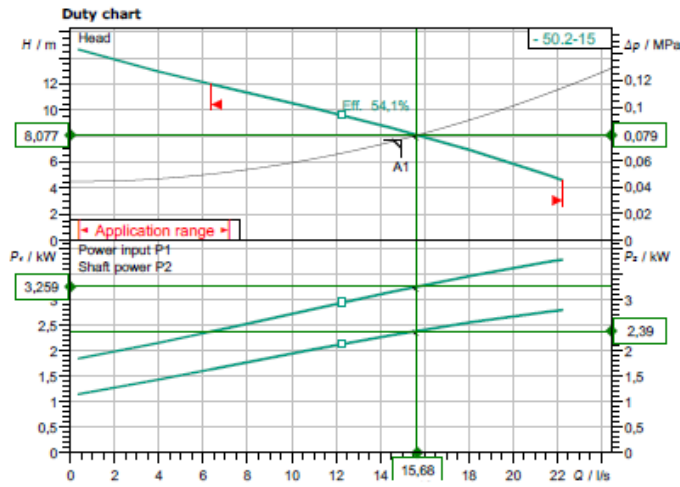

Requested data

Flow	14,94 l/s
Head	7,75 m
Media	Water 100 %
Fluid temperature	20,00 °C
Density	998,30 kg/m ³
Kin. viscosity	1,00 mm ² /s

Hydraulic data (Duty point)

Flow	15,68 l/s
Head	8,08 m

Product data

Solids separation system	EMUport CORE 50.2-15B
No. of pumps	2
Max. operating pressure	0,6 MPa
Fluid temperature	3 °C ... +40 °C
Grinder	no
Operating mode (non-immersed)	S1
Gross volume	1200 l
Max. switching volume	900 l

Motordata per Motor/Pump

Mains connection	3~ 400 V / 50 Hz
Permitted voltage tolerance	±10 %
Nominal speed	1400 1/min
Rated power P2	4,00 kW
Power input P1	0 kW
Rated current	9,50 A
Activation type	Direct online (DOL)
Degree of protection	IP68
Motor protection	WSK
Insulation class	H

Cable

Length of connecting cable	
Mains plug	no
Type of connecting cable	Non-detachable

Fitting dimensions

Venting	Ø 75
Pipe connection on the suction side	DN 200
Pipe connection on the pressure side	DN 100

Materials

Tank material	PE
Pump housing	EN-GJL-250
Impeller	EN-GJL-250
Motor housing	EN-GJL-250

Information for order placements

Weight approx.	700 kg
Item number	6080626



Please initial here (witnesses included)

WILLO EMU-PORT CORE 45.2-13B PS NO 03					JOB NO	
QUOTATION NO:						
ORDER NO:						
INVOICE NO:						
INVOICE DATE:						
SPARES REQUIRED				QUANTITY	COSTING	
EMU-PORT SYSTEM				1		
				Total Cost		
				Sub Total		
DATE COMPLETE				Labour		
SIGNATURE				Quoted Price		

Please initial here (witnesses included)

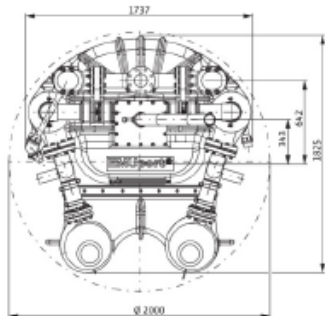
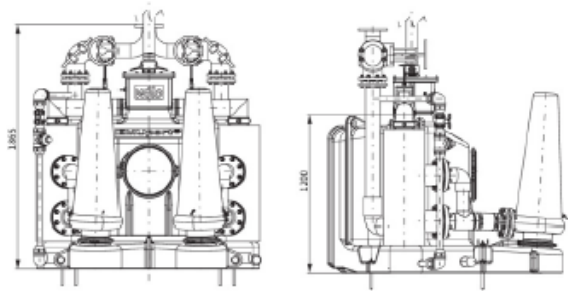
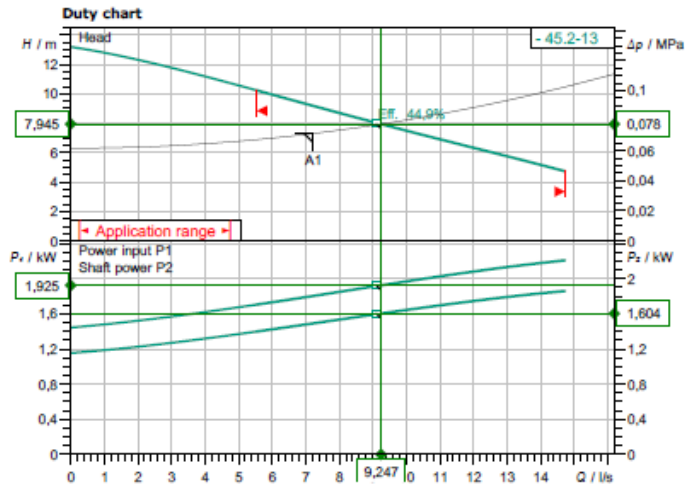

Requested data

Flow	7,21 l/s
Head	7,30 m
Media	Water 100 %
Fluid temperature	20,00 °C
Density	998,30 kg/m ³
Kin. viscosity	1,00 mm ² /s

Hydraulic data (Duty point)

Flow	9,25 l/s
Head	7,94 m

Product data

Solids separation system	EMUport CORE 45.2-13B
No. of pumps	2
Max. operating pressure	0,6 MPa
Fluid temperature	3 °C ... +40 °C
Grinder	no
Operating mode (non-immersed)	S3-50%
Gross volume	1200 l
Max. switching volume	900 l

Motordata per Motor/Pump

Mains connection	3~ 400 V / 50 Hz
Permitted voltage tolerance	±10 %
Nominal speed	2908 1/min
Rated power P2	2,65 kW
Power input P1	0 kW
Rated current	5,70 A
Activation type	Direct online (DOL)
Degree of protection	IP68
Motor protection	WSK
Insulation class	H

Cable

Length of connecting cable	
Mains plug	no
Type of connecting cable	Detachable

Fitting dimensions

Venting	Ø 75
Pipe connection on the suction side	DN 200
Pipe connection on the pressure side	DN 100

Materials

Tank material	PE
Pump housing	EN-GJL-250
Impeller	EN-GJL-250
Motor housing	EN-GJL-250

Information for order placements

Weight approx.	515 kg
Item number	6080608



Please initial here (witnesses included)

WILLO EMU-PORT CORE 45.2-13B PS NO 04					JOB NO	
QUOTATION NO:						
ORDER NO:						
INVOICE NO:						
INVOICE DATE:						
SPARES REQUIRED				QUANTITY	COSTING	
EMU-PORT SYSTEM				1		
				Total Cost		
				Sub Total		
DATE COMPLETE				Labour		
SIGNATURE				Quoted Price		

Please initial here (witnesses included)

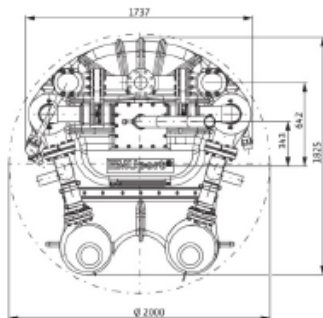
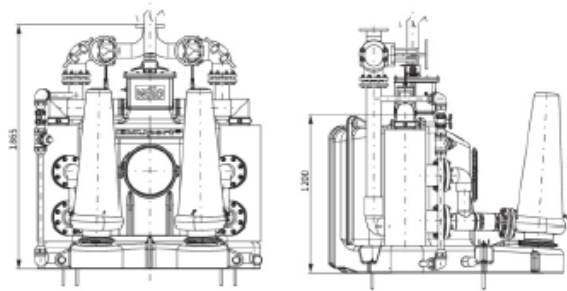
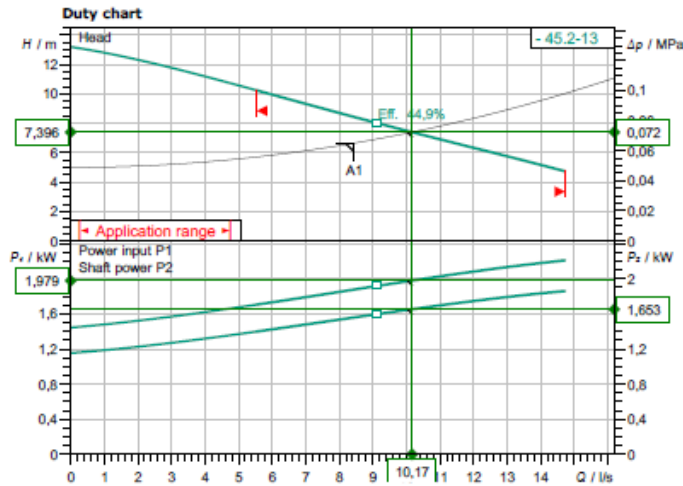

Requested data

Flow	8,44 l/s
Head	6,65 m
Media	Water 100 %
Fluid temperature	20,00 °C
Density	998,30 kg/m ³
Kin. viscosity	1,00 mm ² /s

Hydraulic data (Duty point)

Flow	10,17 l/s
Head	7,40 m

Product data

Solids separation system	EMUport CORE 45.2-13B
No. of pumps	2
Max. operating pressure	0,6 MPa
Fluid temperature	3 °C ... +40 °C
Grinder	no
Operating mode (non-immersed)	S3-50%
Gross volume	1200 l
Max. switching volume	900 l

Motordata per Motor/Pump

Mains connection	3~ 400 V / 50 Hz
Permitted voltage tolerance	±10 %
Nominal speed	2908 1/min
Rated power P_2	2,65 kW
Power input P_1	0 kW
Rated current	5,70 A
Activation type	Direct online (DOL)
Degree of protection	IP68
Motor protection	WSK
Insulation class	H

Cable

Length of connecting cable	
Mains plug	no
Type of connecting cable	Detachable

Fitting dimensions

Venting	Ø 75
Pipe connection on the suction side	DN 200
Pipe connection on the pressure side	DN 100

Materials

Tank material	PE
Pump housing	EN-GJL-250
Impeller	EN-GJL-250
Motor housing	EN-GJL-250

Information for order placements

Weight approx.	515 kg
Item number	6080608



Please initial here (witnesses included)

WILLO EMU-PORT CORE 50.2-17B PS NO 05					JOB NO	
QUOTATION NO:						
ORDER NO:						
INVOICE NO:						
INVOICE DATE:						
SPARES REQUIRED				QUANTITY	COSTING	
EMU-PORT SYSTEM				1		
				Total Cost		
				Sub Total		
DATE COMPLETE				Labour		
SIGNATURE				Quoted Price		

Please initial here (witnesses included)

Date 2020-09-09

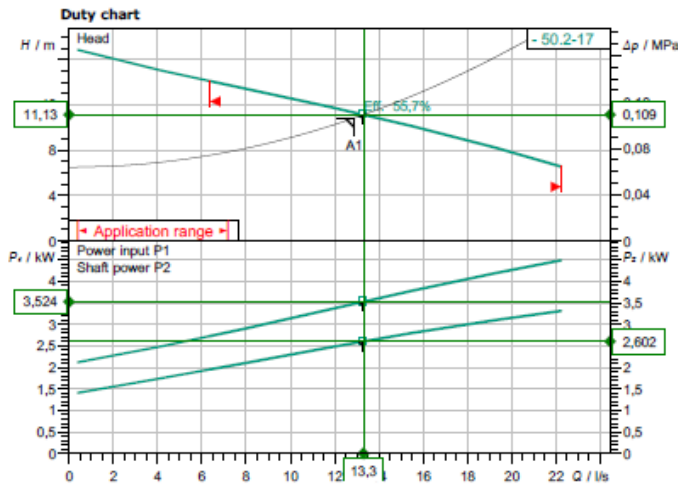

Requested data

Flow	12,86 l/s
Head	10,83 m
Media	Water 100 %
Fluid temperature	20,00 °C
Density	998,30 kg/m ³
Kin. viscosity	1,00 mm ² /s

Hydraulic data (Duty point)

Flow	13,30 l/s
Head	11,13 m

Product data

Solids separation system	EMUport CORE 50.2-17B
No. of pumps	2
Max. operating pressure	0,6 MPa
Fluid temperature	3 °C ... +40 °C
Grinder	no
Operating mode (non-immersed)	S1
Gross volume	1200 l
Max. switching volume	900 l

Motordata per Motor/Pump

Mains connection	3~ 400 V / 50 Hz
Permitted voltage tolerance	±10 %
Nominal speed	1400 1/min
Rated power P2	4,00 kW
Power input P1	0 kW
Rated current	9,50 A
Activation type	Direct online (DOL)
Degree of protection	IP68
Motor protection	WSK
Insulation class	H

Cable

Length of connecting cable	
Mains plug	no
Type of connecting cable	Non-detachable

Fitting dimensions

Venting	Ø 75
Pipe connection on the suction side	DN 200
Pipe connection on the pressure side	DN 100

Materials

Tank material	PE
Pump housing	EN-GJL-250
Impeller	EN-GJL-250
Motor housing	EN-GJL-250

Information for order placements

Weight approx.	700 kg
Item number	6080627

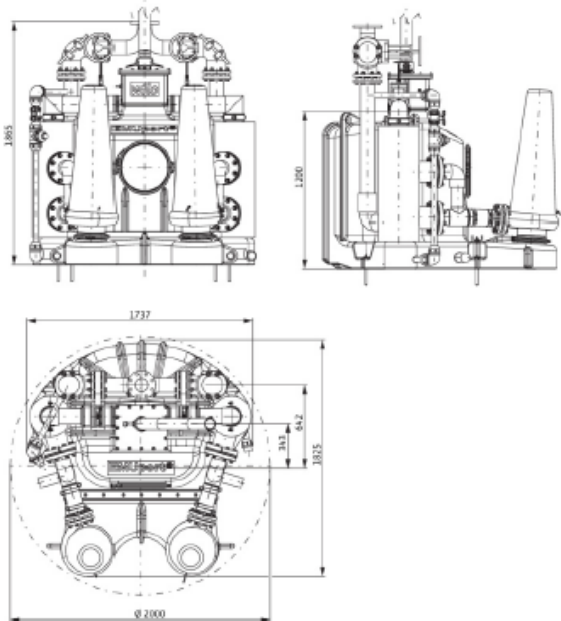

Please initial here (witnesses included)

WILLO EMU-PORT CORE 50.2-20B PS HOOPSTAD TOWN					JOB NO	
QUOTATION NO:						
ORDER NO:						
INVOICE NO:						
INVOICE DATE:						
SPARES REQUIRED				QUANTITY	COSTING	
EMU-PORT SYSTEM				1		
				Total Cost		
				Sub Total		
DATE COMPLETE				Labour		
SIGNATURE				Quoted Price		

Please initial here (witnesses included)

Date 2020-09-09

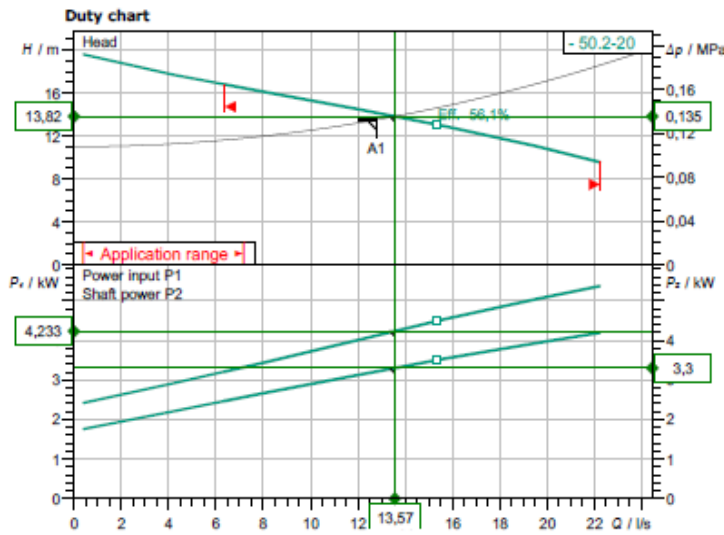

Requested data

Flow	12,77 l/s
Head	13,50 m
Media	Water 100 %
Fluid temperature	20,00 °C
Density	998,30 kg/m ³
Kin. viscosity	1,00 mm ² /s

Hydraulic data (Duty point)

Flow	13,57 l/s
Head	13,82 m

Product data

Solids separation system	EMUport CORE 50.2-20B
No. of pumps	2
Max. operating pressure	0,6 MPa
Fluid temperature	3 °C ... +40 °C
Grinder	no
Operating mode (non-immersed)	S1
Gross volume	1200 l
Max. switching volume	900 l

Motordata per Motor/Pump

Mains connection	3~ 400 V / 50 Hz
Permitted voltage tolerance	±10 %
Nominal speed	1400 1/min
Rated power P2	5,00 kW
Power input P1	0 kW
Rated current	10,80 A
Activation type	Star-delta (SD)
Degree of protection	IP68
Motor protection	WSK
Insulation class	H

Cable

Length of connecting cable	
Mains plug	no
Type of connecting cable	Non-detachable

Fitting dimensions

Venting	Ø 75
Pipe connection on the suction side	DN 200
Pipe connection on the pressure side	DN 100

Materials

Tank material	PE
Pump housing	EN-GJL-250
Impeller	EN-GJL-250
Motor housing	EN-GJL-250

Information for order placements

Weight approx.	700 kg
Item number	6080628

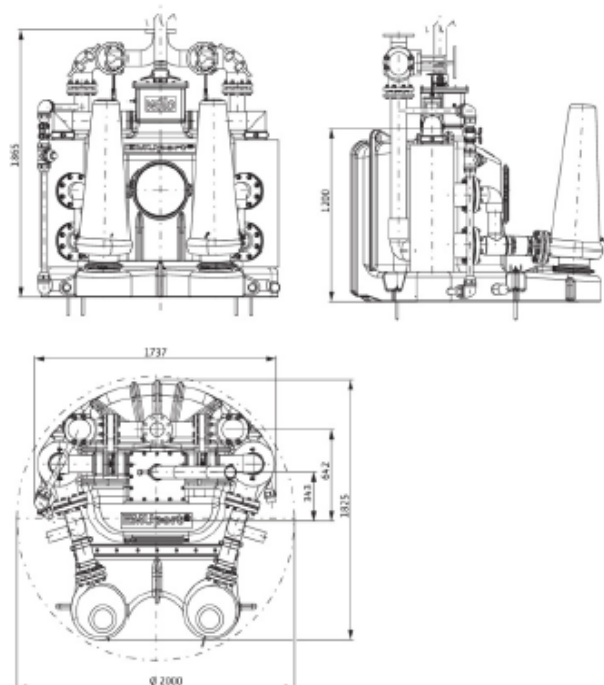

Please initial here (witnesses included)

5. AUTHORITY TO SIGN A BID

COMPANIES AND CLOSE CORPORATIONS

- If a Bidder is a COMPANY, a certified copy of the resolution by the board of directors, duly signed, authorising the person who signs this bid to do so, as well as to sign any contract resulting from this bid and any other documents and correspondence in connection with this bid and/or contract on behalf of the company must be submitted with this bid, that is, before the closing time and date of the bid.
- In the case of a CLOSE CORPORATION (CC) submitting a bid, a resolution by its members, authorizing a member or other official of the corporation to sign the documents on their behalf, shall be included with the bid.

PARTICULARS OF RESOLUTION BY BOARD OF DIRECTORS OF THE COMPANY / MEMBERS OF THE CC

Date Resolution was taken		
Resolution signed by (name and surname)		
Capacity		

Please initial here (witnesses included)

Name and surname of delegated Authorised Signatory		
Capacity		
Specimen Signature		

FULL NAME AND SURNAME OF ALL DIRECTOR(S) / MEMBER (S)	
FULL NAMES	ID NUMBER

Please initial here (witnesses included)

Is a CERTIFIED COPY of the resolution attached?		Yes	No
SIGNED ON BEHALF OF COMPANY / CC			
PRINT NAME			
DATE			

1. SOLE PROPRIETOR (SINGLE OWNER BUSINESS)

I, _____, the undersigned, hereby confirm that I am the sole owner of the business trading as _____

PRINT NAME	
SIGNATURE	
DATE	

2. PARTNERSHIP

We, the undersigned partners in the business trading as _____ hereby authorize Mr/Ms

Please initial here (witnesses included)

_____ to sign this bid as well as any contract resulting from the bid and any other documents and correspondence in connection with this bid and /or contract for and on behalf of the abovementioned partnership.

The following particulars in respect of every partner must be furnished and signed by every partner:

FULL NAME OF PARTNER	SIGNATURE
SIGNED ON BEHALF OF PARTNERSHIP	
PRINT NAME	
DATE	

Please initial here (witnesses included)

**6. GENERAL CONDITIONS OF CONTRACT – GOVERNMENT
PROCUREMENT**

The following terms shall be interpreted as indicated:

- 1.1. "Closing time" means the date and hour specified in the bidding documents for the receipt of bids.
- 1.2. "Contract" means the written agreement entered into between the purchaser and the supplier, as recorded in the contract form signed by the parties, including all attachments and appendices thereto and all documents incorporated by reference therein.
- 1.3. "Contract price" means the price payable to the supplier under the contract for the full and proper performance of his contractual obligations.
- 1.4. "Corrupt practice" means the offering, giving, receiving, or soliciting of anything of value to influence the action of a public official in the procurement process or in contract execution.
- 1.5. "Countervailing duties" are imposed in cases where an enterprise abroad is subsidized by its government and encouraged to market its products internationally.
- 1.6. "Country of origin" means the place where the goods were mined, grown or produced or from which the services are supplied. Goods are produced when, through manufacturing, processing or substantial and major

Please initial here (witnesses included)

assembly of components, a commercially recognized new product results that is substantially different in basic characteristics or in purpose or utility from its components.

- 1.7. "Day" means calendar day.
- 1.8. "Delivery" means delivery in compliance of the conditions of the contract or order.
- 1.9. "Delivery ex stock" means immediate delivery directly from stock actually on hand.
- 1.10. "Delivery into consignees store or to his site" means delivered and unloaded in the specified store or depot or on the specified site in compliance with the conditions of the contract or order, the supplier bearing all risks and charges involved until the supplies are so delivered and a valid receipt is obtained.
- 1.11. "Dumping" occurs when a private enterprise abroad market its goods on own initiative in the RSA at lower prices than that of the country of origin and which have the potential to harm the local industries in the RSA.
- 1.12. "Force majeure" means an event beyond the control of the supplier and not involving the supplier's fault or negligence and not foreseeable.
- 1.13. Such events may include, but is not restricted to, acts of the purchaser in its sovereign capacity, wars or revolutions, fires, floods, epidemics, quarantine restrictions and freight embargoes.

Please initial here (witnesses included)

- 1.14. "Fraudulent practice" means a misrepresentation of facts in order to influence a procurement process or the execution of a contract to the detriment of any bidder, and includes collusive practice among bidders (prior to or after bid submission) designed to establish bid prices at artificial non-competitive levels and to deprive the bidder of the benefits of free and open competition.
- 1.15. "GCC" mean the General Conditions of Contract.
- 1.16. "Goods" means all of the equipment, machinery, and/or other materials that the supplier is required to supply to the purchaser under the contract.
- 1.17. "Imported content" means that portion of the bidding price represented by the cost of components, parts or materials which have been or are still to be imported (whether by the supplier or his subcontractors) and which costs are inclusive of the costs abroad, plus freight and other direct importation costs such as landing costs, dock dues, import duty, sales duty or other similar tax or duty at the South African place of entry as well as transportation and handling charges to the factory in the Republic where the supplies covered by the bid will be manufactured.
- 1.18. "Local content" means that portion of the bidding price which is not included in the imported content provided that local manufacture does take place.
- 1.19. "Manufacture" means the production of products in a factory using labour, materials, components and machinery and includes other related value-adding activities.

Please initial here (witnesses included)

- 1.20. "Order" means an official written order issued for the supply of goods or works or the rendering of a service.
- 1.21. "Project site" where applicable, means the place indicated in bidding documents.
- 1.22. "Purchaser" means the organization purchasing the goods.
- 1.23. "Republic" means the Republic of South Africa.
- 1.24. "SCC" means the Special Conditions of Contract.
- 1.25. "Services" means those functional services ancillary to the supply of the goods, such as transportation and any other incidental services, such as installation, commissioning, provision of technical assistance, training, catering, gardening, security, maintenance and other such obligations of the supplier covered under the contract.
- 1.26. "Supplier" means the successful bidder who is awarded the contract to maintain and administer the required and specified service(s) to the State.
- 1.27. "Tort" means in breach of contract.
- 1.28. "Turnkey" means a procurement process where one service provider assumes total responsibility for all aspects of the project and delivers the full end product / service required by the contract.
- 1.29. "Written" or "in writing" means handwritten in ink or any form of electronic or mechanical writing.

Please initial here (witnesses included)

2. Application

- 2.1. These general conditions are applicable to all bids, contracts and orders including bids for functional and professional services, sales, hiring, letting and the granting or acquiring of rights, but excluding immovable property, unless otherwise indicated in the bidding documents.
- 2.2. Where applicable, special conditions of contract are also laid down to cover specific supplies, services or works.
- 2.3. Where such special conditions of contract are in conflict with these general conditions, the special conditions shall apply.

3. General

- 3.1. Unless otherwise indicated in the bidding documents, the purchaser shall not be liable for any expense incurred in the preparation and submission of a bid. Where applicable a non-refundable fee for documents may be charged.
- 3.2. Invitations to bid are usually published in locally distributed news media and on the municipality / municipal entity website.

4. Standards

- 4.1. The goods supplied shall conform to the standards mentioned in the bidding documents and specifications.

5. Use of contract documents and information; inspection.

Please initial here (witnesses included)

- 5.1. The supplier shall not, without the purchaser's prior written consent, disclose the contract, or any provision thereof, or any specification, plan, drawing, pattern, sample, or information furnished by or on behalf of the purchaser in connection therewith, to any person other than a person employed by the supplier in the performance of the contract. Disclosure to any such employed person shall be made in confidence and shall extend only as far as may be necessary for purposes of such performance.
- 5.2. The supplier shall not, without the purchaser's prior written consent, make use of any document or information mentioned in GCC clause 5.1 except for purposes of performing the contract.
- 5.3. Any document, other than the contract itself mentioned in GCC clause 5.1 shall remain the property of the purchaser and shall be returned (all copies) to the purchaser on completion of the supplier's performance under the contract if so required by the purchaser.
- 5.4. The supplier shall permit the purchaser to inspect the supplier's records relating to the performance of the supplier and to have them audited by auditors appointed by the purchaser, if so required by the purchaser.

6. Patent rights

- 6.1. The supplier shall indemnify the purchaser against all third-party claims of infringement of patent, trademark, or industrial design rights arising from use of the goods or any part thereof by the purchaser.

Please initial here (witnesses included)

6.2. When a supplier developed documentation / projects for the municipality / municipal entity, the intellectual, copy and patent rights or ownership of such documents or projects will vest in the municipality / municipal entity.

7. Performance security

7.1. Within thirty (30) days of receipt of the notification of contract award, the successful bidder shall furnish to the purchaser the performance security of the amount specified in SCC.

7.2. The proceeds of the performance security shall be payable to the purchaser as compensation for any loss resulting from the supplier's failure to complete his obligations under the contract.

7.3. The performance security shall be denominated in the currency of the contract or in a freely convertible currency acceptable to the purchaser and shall be in one of the following forms:

7.3.1. bank guarantee or an irrevocable letter of credit issued by a reputable bank located in the purchaser's country or abroad, acceptable to the purchaser, in the form provided in the bidding documents or another form acceptable to the purchaser; or

7.3.2. a cashier's or certified cheque

7.4. The performance security will be discharged by the purchaser and returned to the supplier not later than thirty (30) days following the date of completion of the supplier's performance obligations under the contract, including any warranty obligations, unless otherwise specified.

Please initial here (witnesses included)

8. Inspections, tests and analyses

- 8.1. All pre-bidding testing will be for the account of the bidder.
- 8.2. If it is a bid condition that supplies to be produced or services to be rendered should at any stage during production or execution or on completion be subject to inspections tests and analysis, the bidder or contractor's premises shall be open, at all reasonable hours, for inspection by a representative of the purchaser or an organization acting on behalf of the purchaser.
- 8.3. If there are no inspection requirements indicated in the bidding documents and no mention is made in the contract, but during the contract period it is decided that inspections shall be carried out, the purchaser shall itself make the necessary arrangements, including payment arrangements with the testing authority concerned.
- 8.4. If the inspections, tests and analyses referred to in clauses 8.2 and 8.3 show the goods to be in accordance with the contract requirements, the cost of the inspections, tests and analyses shall be defrayed by the purchaser.
- 8.5. Where the goods or services referred to in clauses 8.2 and 8.3 do not comply with the contract requirements, irrespective of whether such goods or services are accepted or not, the cost in connection with these inspections, tests or analyses shall be defrayed by the supplier.
- 8.6. Supplies and services which are referred to in clauses 8.2 and 8.3 and which do not comply with the contract requirements may be rejected.

- 8.7. Any contract goods may on or after delivery be inspected, tested or analyzed and may be rejected if found not to comply with the requirements of the contract. Such rejected goods shall be held at the cost and risk of the supplier who shall, when called upon, remove them immediately at his own cost and forthwith substitute them with goods which do comply with the requirements of the contract. Failing such removal the rejected goods shall be returned at the suppliers cost and risk. Should the supplier fail to provide the substitute goods forthwith, the purchaser may, without giving the supplier further opportunity to substitute the rejected goods, purchase such goods as may be necessary at the expense of the supplier.
- 8.8. The provisions of clauses 8.4 to 8.7 shall not prejudice the right of the purchaser to cancel the contract on account of a breach of the conditions thereof, or to act in terms of Clause 22 of GCC.

9. Packing

- 9.1. The supplier shall provide such packing of the goods as is required to prevent their damage or deterioration during transit to their final destination, as indicated in the contract. The packing shall be sufficient to withstand, without limitation, rough handling during transit and exposure to extreme temperatures, salt and precipitation during transit, and open storage. Packing, case size and weights shall take into consideration, where appropriate, the remoteness of the goods' final destination and the absence of heavy handling facilities at all points in transit.
- 9.2. The packing, marking, and documentation within and outside the packages shall comply strictly with such special requirements as shall be

Please initial here (witnesses included)

expressly provided for in the contract, including additional requirements, and in any subsequent instructions ordered by the purchaser.

10. Delivery

10.1. Delivery of the goods shall be made by the supplier in accordance with the documents and terms specified in the contract. The details of shipping and/or other documents to be furnished by the supplier are specified.

11. Insurance

11.1. The goods supplied under the contract shall be fully insured in a freely convertible currency against loss or damage incidental to manufacture or acquisition, transportation, storage and delivery in the manner specified.

12. Transportation

12.1. Should a price other than an all-inclusive delivered price be required, this shall be specified.

13. Incidental

13.1. The supplier may be required to provide any or all of the following services, including additional services, if any:

13.1.1. performance or supervision of on-site assembly and/or commissioning of the supplied goods;

13.1.2. furnishing of tools required for assembly and/or maintenance of the supplied goods;

13.1.3. furnishing of a detailed operations and maintenance manual for each appropriate unit of the supplied goods;

13.1.4. performance or supervision or maintenance and/or repair of the supplied goods, for a period of time agreed by the parties, provided that this service shall not relieve the supplier of any warranty obligations under this contract; and

13.1.5. training of the purchaser's personnel, at the supplier's plant and/or on-site, in assembly, start-up, operation, maintenance, and/or repair of the supplied goods.

13.2. Prices charged by the supplier for incidental services, if not included in the contract price for the goods, shall be agreed upon in advance by the parties and shall not exceed the prevailing rates charged to other parties by the supplier for similar service

14. Spare parts

14.1. As specified, the supplier may be required to provide any or all of the following materials, notifications, and information pertaining to spare parts manufactured or distributed by the supplier:

14.1.1. such spare parts as the purchaser may elect to purchase from the supplier, provided that this election shall not relieve the supplier of any warranty obligations under the contract; and;

14.1.2. in the event of termination of production of the spare parts:

14.1.2.1. advance notification to the purchaser of the pending termination, in sufficient time to permit the purchaser to procure needed requirements; and

14.1.2.2. following such termination, furnishing at no cost to the purchaser, the blueprints, drawings, and specifications of the spare parts, if requested.

15. Warranty

15.1. The supplier warrants that the goods supplied under the contract are new, unused, of the most recent or current models, and that they incorporate all recent improvements in design and materials unless provided otherwise in the contract. The supplier further warrants that all goods supplied under this contract shall have no defect, arising from design, materials, or workmanship (except when the design and/or material is required by the purchaser's specifications) or from any act or omission of the supplier, that may develop under normal use of the supplied goods in the conditions prevailing in the country of final destination.

15.2. This warranty shall remain valid for twelve (12) months after the goods, or any portion thereof as the case may be, have been delivered to and accepted at the final destination indicated in the contract, or for eighteen (18) months after the date of shipment from the port or place of loading in the source country, whichever period concludes earlier, unless specified otherwise in SCC.

- 15.3. The purchaser shall promptly notify the supplier in writing of any claims arising under this warranty.
- 15.4. Upon receipt of such notice, the supplier shall, within the period specified in SCC and with all reasonable speed, repair or replace the defective goods or parts thereof, without costs to the purchaser.
- 15.5. If the supplier, having been notified, fails to remedy the defect(s) within the period specified, the purchaser may proceed to take such remedial action as may be necessary, at the supplier's risk and expense and without prejudice to any other rights which the purchaser may have against the supplier under the contract.

16. Payment

- 16.1. The method and conditions of payment to be made to the supplier under this contract shall be specified.
- 16.2. The supplier shall furnish the purchaser with an invoice accompanied by a copy of the delivery note and upon fulfilment of other obligations stipulated in the contract.
- 16.3. Payments shall be made by the purchaser **no later than thirty (30) days** after submission of an **invoice, statement** or claim by the supplier.
- 16.4. Payment will be made in Rand unless otherwise stipulated.

17. Prices

Please initial here (witnesses included)

17.1. Prices charged by the supplier for goods delivered and services performed under the contract shall not vary from the prices quoted by the supplier in his bid, with the exception of any price adjustments authorized or in the purchaser's request for bid validity extension, as the case may be.

18. Variation orders

18.1. In cases where the estimated value of the envisaged changes in purchase does not vary more than 15% of the total value of the original contract, the contractor may be instructed to deliver the goods or render the services as such. In cases of measurable quantities, the contractor may be approached to reduce the unit price and such offers, may be accepted provided that there is no escalation in price.

19. Assignment

19.1. The supplier shall not assign, in whole or in part, its obligations to perform under the contract, except with the purchaser's prior written consent.

20. Subcontracts

20.1. The supplier shall notify the purchaser in writing of all subcontracts awarded under this contract, if not already specified in the bid. Such notification, in the original bid or later, shall not relieve the supplier from any liability or obligation under the contract.

21. Delays in the supplier's performance

Please initial here (witnesses included)

- 21.1. Delivery of the goods and performance of services shall be made by the supplier in accordance with the time schedule prescribed by the purchaser in the contract.
- 21.2. If at any time during performance of the contract, the supplier or its subcontractor(s) should encounter conditions impeding timely delivery of the goods and performance of services, the supplier shall promptly notify the purchaser in writing of the fact of the delay, its likely duration and its cause(s). As soon as practicable after receipt of the supplier's notice, the purchaser shall evaluate the situation and may at his discretion extend the supplier's time for performance, with or without the imposition of penalties, in which case the extension shall be ratified by the parties by amendment of contract.
- 21.3. The right is reserved to procure outside of the contract small quantities or to have minor essential services executed if an emergency arises, the supplier's point of supply is not situated at or near the place where the supplies are required, or the supplier's services are not readily available.
- 21.4. Except as provided under GCC Clause 25, a delay by the supplier in the performance of its delivery obligations shall render the supplier liable to the imposition of penalties, pursuant to GCC Clause 22, unless an extension of time is agreed upon pursuant to GCC Clause 22 without the application of penalties.
- 21.5. Upon any delay beyond the delivery period in the case of a supplies contract, the purchaser shall, without cancelling the contract, be entitled to purchase supplies of a similar quality and up to the same quantity in substitution of the goods not supplied in conformity with the contract and

Please initial here (witnesses included)

to return any goods delivered later at the supplier's expense and risk, or to cancel the contract and buy such goods as may be required to complete the contract and without prejudice to his other rights, be entitled to claim damages from the supplier.

22. Penalties

22.1. Subject to GCC Clause 25, if the supplier fails to deliver any or all of the goods or to perform the services within the period(s) specified in the contract, the purchaser shall, without prejudice to its other remedies under the contract, deduct from the contract price, as a penalty, a sum calculated on the delivered price of the delayed goods or unperformed services using the current prime interest rate calculated for each day of the delay until actual delivery or performance. The purchaser may also consider termination of the contract pursuant to GCC Clause 23.

23. Termination for default

23.1. The purchaser, without prejudice to any other remedy for breach of contract, by written notice of default sent to the supplier, may terminate this contract in whole or in part:

23.1.1. if the supplier fails to deliver any or all of the goods within the period(s) specified in the contract, or within any extension thereof granted by the purchaser pursuant to GCC Clause 21.2;

23.1.2. if the Supplier fails to perform any other obligation(s) under the contract; or

- 23.1.3. if the supplier, in the judgment of the purchaser, has engaged in corrupt or fraudulent practices in competing for or in executing the contract.
- 23.2. In the event the purchaser terminates the contract in whole or in part, the purchaser may procure, upon such terms and in such manner as it deems appropriate, goods, works or services similar to those undelivered, and the supplier shall be liable to the purchaser for any excess costs for such similar goods, works or services. However, the supplier shall continue performance of the contract to the extent not terminated.
- 23.3. Where the purchaser terminates the contract in whole or in part, the purchaser may decide to impose a restriction penalty on the supplier by prohibiting such supplier from doing business with the public sector for a period not exceeding 10 years.
- 23.4. If a purchaser intends imposing a restriction on a supplier or any person associated with the supplier, the supplier will be allowed a time period of not more than fourteen (14) days to provide reasons why the envisaged restriction should not be imposed. Should the supplier fail to respond within the stipulated fourteen (14) days the purchaser may regard the supplier as having no objection and proceed with the restriction
- 23.5. Any restriction imposed on any person by the purchaser will, at the discretion of the purchaser, also be applicable to any other enterprise or any partner, manager, director or other person who wholly or partly exercises or exercised or may exercise control over the enterprise of the first mentioned person, and with which enterprise or person the first-

Please initial here (witnesses included)

mentioned person, is or was in the opinion of the purchase actively associated.

23.6. If a restriction is imposed, the purchaser must, within five (5) working days of such imposition, furnish the National Treasury, with the following information:

23.6.1. the name and address of the supplier and / or person restricted by the purchaser;

23.6.2. the date of commencement of the restriction

23.6.3. the period of restriction; and

23.6.4. the reasons for the restriction.

These details will be loaded in the National Treasury's central database of suppliers or persons prohibited from doing business with the public sector.

23.7. If a court of law convicts a person of an offence as contemplated in sections 12 or 13 of the Prevention and Combating of Corrupt Activities Act, No. 12 of 2004, the court may also rule that such person's name be endorsed on the Register for Tender Defaulters. When a person's name has been endorsed on the Register, the person will be prohibited from doing business with the public sector for a period not less than five years and not more than 10 years. The National Treasury is empowered to determine the period of restriction and each case will be dealt with on its own merits. According to section 32 of the Act the Register must be open to the public. The Register can be perused on the National Treasury website.

24. Anti-dumping and countervailing duties and rights

Page 118 of 177

Please initial here (witnesses included)

24.1. When, after the date of bid, provisional payments are required, or antidumping or countervailing duties are imposed, or the amount of a provisional payment or anti-dumping or countervailing right is increased in respect of any dumped or subsidized import, the State is not liable for any amount so required or imposed, or for the amount of any such increase. When, after the said date, such a provisional payment is no longer required or any such anti-dumping or countervailing right is abolished, or where the amount of such provisional payment or any such right is reduced, any such favourable difference shall on demand be paid forthwith by the contractor to the State or the State may deduct such amounts from moneys (if any) which may otherwise be due to the contractor in regard to supplies or services which he delivered or rendered, or is to deliver or render in terms of the contract or any other contract or any other amount which may be due to him.

25. Force Majeure

25.1. Notwithstanding the provisions of GCC Clauses 22 and 23, the supplier shall not be liable for forfeiture of its performance security, damages, or termination for default if and to the extent that his delay in performance or other failure to perform his obligations under the contract is the result of an event of force majeure.

25.2. If a force majeure situation arises, the supplier shall promptly notify the purchaser in writing of such condition and the cause thereof. Unless otherwise directed by the purchaser in writing, the supplier shall continue to perform its obligations under the contract as far as is reasonably

Please initial here (witnesses included)

practical, and shall seek all reasonable alternative means for performance not prevented by the force majeure event.

26. Termination for insolvency

26.1. The purchaser may at any time terminate the contract by giving written notice to the supplier if the supplier becomes bankrupt or otherwise insolvent. In this event, termination will be without compensation to the supplier, provided that such termination will not prejudice or affect any right of action or remedy which has accrued or will accrue thereafter to the purchaser.

27. Settlement of Disputes

27.1. If any dispute or difference of any kind whatsoever arises between the purchaser and the supplier in connection with or arising out of the contract, the parties shall make every effort to resolve amicably such dispute or difference by mutual consultation.

27.2. If, after thirty (30) days, the parties have failed to resolve their dispute or difference by such mutual consultation, then either the purchaser or the supplier may give notice to the other party of his intention to commence with mediation. No mediation in respect of this matter may be commenced unless such notice is given to the other party.

27.3. Should it not be possible to settle a dispute by means of mediation, it may be settled in a South African court of law.

27.4. Notwithstanding any reference to mediation and/or court proceedings herein,

27.4.1. the parties shall continue to perform their respective obligations under the contract unless they otherwise agree; and

27.4.2. the purchaser shall pay the supplier any monies due for goods delivered and / or services rendered according to the prescripts of the contract.

28. Limitation of liability

28.1. Except in cases of criminal negligence or wilful misconduct, and in the case of infringement pursuant to Clause 6;

28.1.1. the supplier shall not be liable to the purchaser, whether in contract, tort, or otherwise, for any indirect or consequential loss or damage, loss of use, loss of production, or loss of profits or interest costs, provided that this exclusion shall not apply to any obligation of the supplier to pay penalties and/or damages to the purchaser; and

28.1.2. the aggregate liability of the supplier to the purchaser, whether under the contract, in tort or otherwise, shall not exceed the total contract price, provided that this limitation shall not apply to the cost of repairing or replacing defective equipment

29. Governing language

Please initial here (witnesses included)

29.1. The contract shall be written in English. All correspondence and other documents pertaining to the contract that is exchanged by the parties shall also be written in English.

30. Applicable law

30.1. The contract shall be interpreted in accordance with South African laws, unless otherwise specified.

31. Notices

31.1. Every written acceptance of a bid shall be posted to the supplier concerned by registered or certified mail and any other notice to him shall be posted by ordinary mail to the address furnished in his bid or to the address notified later by him in writing and such posting shall be deemed to be proper service of such notice.

31.2. The time mentioned in the contract documents for performing any act after such aforesaid notice has been given, shall be reckoned from the date of posting of such notice.

32. Taxes and duties

32.1. A foreign supplier shall be entirely responsible for all taxes, stamp duties, license fees, and other such levies imposed outside the purchaser's country.

Please initial here (witnesses included)

- 32.2. A local supplier shall be entirely responsible for all taxes, duties, license fees, etc., incurred until delivery of the contracted goods to the purchaser.
- 32.3. No contract shall be concluded with any bidder whose tax matters are not in order. Prior to the award of a bid SARS must have certified that the tax matters of the preferred bidder are in order.
- 32.4. No contract shall be concluded with any bidder whose municipal rates and taxes and municipal services charges are in arrears.

33. Transfer of contracts

- 33.1. The contractor shall not abandon, transfer, cede, assign or sublet a contract or part thereof without the written permission of the purchaser.

34. Amendment of contracts

- 34.1. No agreement to amend or vary a contract or order or the conditions, stipulations or provisions thereof shall be valid and of any force unless such agreement to amend or vary is entered into in writing and signed by the contracting parties. Any waiver of the requirement that the agreement to amend or vary shall be in writing, shall also be in writing.

35. Prohibition of restrictive practices.

- 35.1. In terms of section 4 (1) (b) (iii) of the Competition Act No. 89 of 1998, as amended, an agreement between, or concerted practice by, firms, or a decision by an association of firms, is prohibited if it is between parties in a

Please initial here (witnesses included)

horizontal relationship and if a bidder(s) is / are or a contractor(s) was / were involved in collusive bidding.

35.2. If a bidder(s) or contractor(s) based on reasonable grounds or evidence obtained by the purchaser has / have engaged in the restrictive practice referred to above, the purchaser may refer the matter to the Competition Commission for investigation and possible imposition of administrative penalties as contemplated in section 59 of the Competition Act No 89 Of 1998.

35.3. If a bidder(s) or contractor(s) has / have been found guilty by the Competition Commission of the restrictive practice referred to above, the purchaser may, in addition and without prejudice to any other remedy provided for, invalidate the bid(s) for such item(s) offered, and / or terminate the contract in whole or part, and / or restrict the bidder(s) or contractor(s) from conducting business with the public sector for a period not exceeding ten (10) years and / or claim damages from the bidder(s) or contractor(s) concerned

Please initial here (witnesses included)

7. GENERAL CONDITIONS OF TENDER

1. Sealed tenders, with the “**Tender Number and Title**” clearly endorsed on the envelope, and must be deposited in the **tender box indicated** at the offices of Tswelopele Local Municipality, at Bultfontein. Refer to the tender advert for full details.
2. The tender must be lodged by the Tenderer in the tender box as indicated in the tender advertisement.
3. Tenders that are deposited in the incorrect box will not be considered.
4. Mailed, telegraphic or faxed tenders will not be accepted.
5. Documents may only be completed in black ink.
6. In the event of a mistake having been made, it shall be crossed out in ink and be accompanied by an initial at each and every alteration.
7. Alterations or deletions not signed by the Tenderer may render the tender invalid.
8. All bids must be submitted in writing on the official forms supplied (not to be re-typed).
9. All prices shall be quoted in South African currency and be **INCLUSIVE of VAT.**

Please initial here (witnesses included)

10. Any Tender received after the closing date and time of Tenders shall not be considered but shall be filed unopened with the other Tenders received or may be returned to the Tenderer at his request and for his/ her cost.
11. Tenders may not be telefaxed to the Municipality and therefore any tenders received by fax will **not** be considered.
12. A separate Tender box is provided for the reception of Tenders and no Tender will be considered which, subsequent to the closing hour for Tenders, may be found in another box.
13. Tenders shall be opened in public at the Tswelopele Municipal Offices as soon as possible after the closing time for the receipt of tenders (if there are tenderers that are available during the closing time and date).
14. The Municipality shall have the right to summarily disqualify any Tenderer who, either at the date of submission of this tender or at the date of its award, is indebted to the Municipality in respect of any rental, levies, rates and/or service charges.
15. This bid will be evaluated and adjudicated according to the following criteria:
 - a. Relevant specifications
 - b. Value for money
 - c. Capability to execute the contract
 - d. PPPFA & associated regulations

Please initial here (witnesses included)

16. Tax invoices are to comply with the requirements as contained in the Value Added Tax Act, Act 89 of 1991. The content of the invoice must contain sufficient information for audit purposes.
17. It is a requirement of this contract that the amount of value-added tax (VAT) must be shown clearly on each invoice.
18. The amended Value-Added Tax Act requires that a Tax Invoice for supplies in excess of R3,000 should, in addition to the other required information, also disclose the VAT registration number of the recipient, with effect from 1 March 2005.
19. The VAT registration number of the Municipality is 4000846487.
20. All money owed by the municipality must be paid within 30 calendar days of receiving the relevant invoice or statement, unless prescribed otherwise for certain categories of expenditure.

Please initial here (witnesses included)

8. OCCUPATIONAL HEALTH AND SAFETY

**SECTION 37(2) OF THE OCCUPATIONAL HEALTH AND SAFETY ACT, 1993
(ACT 85 OF 1993)**

WRITTEN AGREEMENT

**THIS IS IN TERMS OF SECTION 37(2) OF THE OCCUPATIONAL HEALTH AND
SAFETY ACT, 1993 (ACT 85 OF 1993)**

BETWEEN:

TSWELOPELE LOCAL MUNICIPALITY

AND

(Mandatory: Name of the bidder)

INTRODUCTION

The Occupational Health and Safety Act, 1993 (Act 85 of 1993) stipulates that the Chief Executive Officer is primarily responsible or liable for the health and safety of all his/her employees. This is embedded in Section 16(1) of the said Act. This responsibility or liability is also extended to include a mandatory that performs work on behalf of the employer on his/her premises.

Please initial here (witnesses included)

A “mandatary” is defined in the said Act as: - *“Including an agent, contractor or subcontractor for work, but without derogating from his status in his own right as an employer or user”*

In terms of Section 37(2), read with Section 41, of the said Act, it is legally possible for an employer to indemnify himself from this responsibility or liability regarding the actions of the mandatary. Section 37(2) stipulates that there should be a written agreement in place between the employer and the mandatary regarding the arrangements and procedures between them to ensure compliance by the mandatary with the provisions of the Occupational Health and Safety Act, 1993.

By ensuring that there is a written agreement in place, the Management of Tswelopele Local Municipality is acting in a responsible manner, so as to ensure that this requirement is indeed being met.

In order to ensure that this written agreement is honoured at all times, regular inspections of work that is performed will be conducted and if found not complying with the said agreement, a notice of noncompliance will be issued. All work will be stopped and reasons for non-compliance must be given and what corrective action will be taken to rectify the situation must be stipulated.

SIGNED – MANAGEMENT:	
-----------------------------	--

WRITTEN AGREEMENT

This is a written agreement between
Tswelopele local municipality

Please initial here (witnesses included)

And

(Name of the MANDATARY)

In terms Section 37(2) of the Occupational Health and Safety Act, 1993 (Act 85 of 1993) as amended.

I, _____ representing the MANDATARY do hereby acknowledge that (*mandatary*) is an employer in its own right with duties as prescribed in the Occupational Health and Safety Act, 1993 (Act 85 of 1993) as amended and agree to ensure that all work that will be performed, any article or substance that will be produced, processed, used, handled, stored or transported and plant and machinery that will be used, will be done in accordance with the provisions of the said Act.

I furthermore agree to comply with the Health and Safety requirements and to liaise with the Municipality should I, for whatever reason, be unable to perform in terms of this Agreement.

SIGNED ON BEHALF OF MANDATORY	
PLACE	
PRINT NAME	
CAPACITY	
SIGNATURE	

Please initial here (witnesses included)

DATE	
SIGNED ON BEHALF OF THE MUNICIPALITY	
PLACE	
PRINT NAME	
CAPACITY	
SIGNATURE	
DATE	

**COMPENSATION FOR OCCUPATIONAL INJURIES AND DISEASES ACT,
1993 (ACT 130 OF 1993)**

_____ <i>(Municipality)</i>
<p>has legal duty in terms of Section 89 of the said Act to ensure that all contractors with whom agreements are entered into for the execution of work are registered as employers in accordance with the provisions of this Act and that all the necessary assessments have been paid by the contractor.</p> <p>In order to enter into this agreement, the following information is needed regarding the abovementioned:</p>

Please initial here (witnesses included)

CONTRACTOR'S REGISTRATION NUMBER WITH THE OFFICE OF THE COMPENSATION COMMISSIONER	
PROOF THAT ASSESSMENT HAS BEEN PAID	A copy of the latest receipt together with a copy of the relevant assessment OR a copy of a valid Letter of Good Standing must be handed in, in this regard.
SIGNATURE OF CONTRACTOR	
DATE	

9. FORM OF INDEMNITY

INDEMNITY

Given by (Name of Company) _____

of (registered address of Company) _____

Please initial here (witnesses included)

a company incorporated with limited liability according to the Company Laws of the Republic of South Africa (hereinafter called the Contractor), represented herein by (Name of Representative) _____

in his capacity as (Designation) _____

of the Contractor, is duly authorised hereto by a resolution dated _____ to sign on behalf of the Contractor.

WHEREAS the Contractor has entered into a Contract dated _____ with the Municipality who require this indemnity from the Contractor.

NOW THEREFORE THIS DEED WITNESSES that the Contractor does hereby indemnify and hold harmless the Municipality in respect of all loss or damage that may be incurred or sustained by the Municipality by reason of or in any way arising out of or caused by operations that may be carried out by the Contractor in connection with the aforementioned contract; and also in respect of all claims that may be made against the Municipality in consequence of such operations, by reason of or in any way arising out of any accidents or damage to life or property or any other cause whatsoever; and also in respect of all legal or other expenses that may be incurred by the Municipality in examining, resisting or settling any such claims; for the due performance of which the Contractor binds itself according to law.

SIGNATURE OF CONTRACTOR	
SIGNED AT (PLACE)	

Please initial here (witnesses included)

NAME OF THE CONTRACTOR	
DATE	

Please initial here (witnesses included)

10. SPECIFICATIONS

1. Background

- 1.1 The Tswelopele Local Municipality requires a supplier who will repair and maintain sewerage pumps as and when required for a contract period ending 30 June 2026.
- 1.2 The successful tenderer will be required to render the above services upon receipt of the Official Order from the municipality during the validity of the contract.

2. Public Liability

- 2.1 The municipality shall not be liable in respect of any claims, damages, accidents, etc. to persons, properties, vehicle rights, etc. that may arise from the carrying out of this contract.

3. Safety

- 1.1. The tenderer must comply with the relevant conditions of the Occupational Health and Safety Act.
- 1.2. The tenderer must provide emergency contact details of a responsible person who can deal with any situation arising from a delivery or any other problem directly linked to this services.

4. Training

1.1 It will be required of the successful tenderer to train the operators (in each town / plant) in the safe use of the chemicals upon the first usage of the chemical and issue a certificate to that effect to the municipality.

1.2 Monitoring should be done and reported to the Municipal Manager every two weeks for the first three months and thereafter a monthly report should be provided to the Municipal Manager till expiry of the contract.

5. Repairs and Maintenance

5.1 Tendered prices must include collection of the pumps from the municipality; delivery after repairs and offloading in the respective towns.

5.2 Deliveries to reach sites during normal working hours between the hours of 08H00 and 15H00, unless otherwise agreed by the Director Technical Services.

5.3 Tenderers must acquaint themselves with the condition of the access roads/delivery points to ensure effective deliveries.

6. Pricing

7.1 The tenderer must complete the pricing schedule in this tender document and failure to do so may lead to the tender being disqualified.

7.2 All amounts must be quoted in Rands and must include Value Added Tax where the tenderer is registered

7. Escalation

8.1 Escalation of prices is allowed and the tenderer must indicate escalation prices (in percentage terms). All escalation prices shall be accounted for in determining the total cost of the bid for the purpose of calculating the bid prices for the duration of the contract.

8.2 The escalation fee / percentage must be linked to the municipal financial year (i.e. the first escalation will be with effect from 01 July 2024).

8.3 Where the price of parts is affected by fluctuations in the exchange rate, such variations will only be allowed upon submission of proof supporting such claims.

8. Awarding of tenders

9.1 Tenderers may tender for any or all of the items, and the municipality may award the tender for any or all items.

9.2 In addition to the conditions herein, the municipality will enter into a Service Level Agreement with the successful tender.

9.3 The municipality will place orders for services required under this contract “as and when required” basis during the validity period of the contract.

9. Termination of contract

10.1 The Municipality may terminate the contract should the tenderer not comply with any of the tender specifications or default after the contract has been awarded.

10. Contract period

- a. This contract validity period is from the date of appointment until **30 June 2026**

11. Validity period

- a. Tender prices must remain valid for a period of **90 days** (calculated from closing date of the tender).

12. Occupational Health and Safety / COIDA

- a. The successful tenderer must comply with the provisions of the Occupational Health and Safety Act.

13. Testing bay

14.1 The tenderer shall submit a letter of intent of the test bay or letter of the approved and working test, failing which, the tender will not be evaluated further.

14. Declaration

- a. I/ We hereby agree to render all of the services described on the terms and conditions and in accordance with the specifications stipulated at the prices and on the terms described herein.
- b. I/ We agree that the herein shall remain binding upon me/us during the validity period of contract.

SIGNATURE	
NAME (PRINT)	

Please initial here (witnesses included)

CAPACITY	
NAME OF FIRM	

11. FORM OF OFFER AND PRICING

1. OFFER

The Employer, identified in the Acceptance signature block, has solicited offers to enter into a contract in respect of the following works: Tender Number - **SCM/TSW18/2023-2024: REPAIRS AND MAINTENANCE OF SEWERAGE PUMPS WITHIN TSWELOPELE LOCAL MUNICIPALITY FOR THE PERIOD ENDING 30 JUNE 2026**

- 1.1. All delivery and off-loading costs **MUST** be included in the bid price, for delivery at the prescribed destination.
- 1.2. Document **MUST** be completed in non-erasable black ink and **NO** correction fluid/tape may be used.
- 1.3. Tswelopele Local Municipality does not bind itself to accept the lowest or any tender and reserves the right to accept any tender or part thereof, as it may deem expedient.
- 1.4. All prices shall be quoted in South African currency and be **INCLUSIVE** of VAT (see table below for completion of prices).

Please initial here (witnesses included)

- 1.5. The tenderer, identified in the Offer signature block, has examined the draft contract as listed in the Acceptance Section and agreed to provide this Offer.
- 1.6. By the representative of the Tenderer, deemed to be duly authorised, signing this part of this Form of Offer and Acceptance, the Tenderer offers to perform all of the obligations and liabilities of the Employer under the contract, including compliance with all its terms and conditions according to their true intent and meaning for an amount to be determined in accordance with the conditions of contract identified in the Contract Data.

2. ACCEPTANCE

- 2.1. By signing this part of this Form of Offer and Acceptance, the Employer identified below accepts the tenderer's Offer. In consideration thereof, the Employer shall pay the Contractor the amount due in accordance with the conditions of contract identified in the Contract Data.
- 2.2. Acceptance of the tenderer's Offer shall form an agreement between the Employer and the tenderer upon the terms and conditions contained in this agreement and in the contract that is the subject of this agreement.
- 2.3. Deviations from and amendments to the documents listed in the Tender Data and any addenda thereto listed in the Returnable Schedules as well as any changes to the terms of the Offer agreed by the tenderer and the Employer during this process of offer and acceptance, are contained in the

Please initial here (witnesses included)

Schedule of Deviations attached to and forming part of this Form of Offer and Acceptance. No amendments to or deviations from said documents are valid unless contained in this Schedule.

- 2.4. It is expressly agreed that no other matter whether in writing, oral communication or implied during the period between the issue of the tender documents and the receipt by the tenderer of a completed signed copy of this Agreement shall have any meaning or effect in the contract between the parties arising from this agreement.

- 2.5. The Employer can enter into a separate service level agreement with the supplier for the purpose of executing this contract.

Please initial here (witnesses included)



TSWELOPELE

LOCAL MUNICIPALITY
A MUNICIPALITY IN PROGRESS

MBD 1

INVITATION TO BID

YOU ARE HEREBY INVITED TO BID FOR REQUIREMENTS OF THE
TSWELOPELE LOCAL MUNICIPALITY

BID/TENDER NUMBER: _____

CLOSING DATE: _____

CLOSING TIME: _____

DESCRIPTION: _____

Please initial here (witnesses included)

The successful bidder will be required to fill in and sign a written Contract Form (MBD 7).

DEPOSITED IN THE BID BOX SITUATED AT:

Reception Area on the Ground Floor
Tswelopele Local Municipality Offices
01 Bosman Street, Civic Centre;
Bultfontein
9670

Bidders/Tenderers should ensure that bids are delivered timeously to the correct address. If the bid is late, it will not be accepted for consideration. The bid box is generally open from 07H30 till 16H00 from Monday till Friday excluding public Holidays.

ALL BIDS MUST BE SUBMITTED ON THE OFFICIAL FORMS / TENDER DOCUMENTS ISSUED BY THE MUNICIPALITY

(NOT TO BE RE-TYPED)

THIS BID IS SUBJECT TO THE GENERAL CONDITIONS OF CONTRACT (GCCP) AND, IF APPLICABLE, ANY OTHER SPECIAL CONDITIONS OF CONTRACT

Please initial here (witnesses included)

THIS BID WILL BE EVALUATED AND ADJUDICATED ACCORDING TO THE FOLLOWING CRITERIA:

1. Relevant specifications
2. Value for money
3. Capability to execute the contract
4. PPPFA & associated regulations

NB: NO BIDS WILL BE CONSIDERED FROM PERSONS IN THE SERVICE OF THE STATE (see definition on MBD 4 attached)

THE FOLLOWING PARTICULARS MUST BE FURNISHED (FAILURE TO DO SO MAY RESULT IN YOUR BID BEING DISQUALIFIED)

NAME OF BIDDER: _____

POSTAL ADDRESS: _____

Please initial here (witnesses included)

STREET ADDRESS: _____

TELEPHONE NUMBER: _____

CELLPHONE NUMBER: _____

FACSIMILE NUMBER: _____

VAT REGISTRATION NUMBER: _____

HAS AN ORIGINAL TAX CLEARANCE CERTIFICATE BEEN ATTACHED (MBD 2)?

YES / NO

ARE YOU THE ACCREDITED REPRESENTATIVE IN SOUTH AFRICA FOR THE GOODS/SERVICES OFFERED BY YOU?

Please initial here (witnesses included)

YES / NO (IF YES ENCLOSE PROOF)

SIGNATURE OF BIDDER	
CAPACITY / POSITION	
DATE	
TOTAL BID PRICE	
(THIS PRICE MUST BE THE SAME AS THE ONE INDICATED IN THE FORM OF OFFER. IF AMOUNTS ARE DIFFERENT, THE AMOUNT SHOWN IN THE FORM OF OFFER WILL BE CONSIDERED)	
TOTAL NUMBER OF ITEMS OFFERED	As per the required quantities

ANY ENQUIRIES REGARDING THE BIDDING PROCEDURE AND TECHNICAL INFORMATION MAY BE DIRECTED TO:

Municipality: Tswelopele Local Municipality

Contact Person: Puseletso Mashiane

Tel: (051) 853 1111

Please initial here (witnesses included)



MBD 2
TAX CLEARANCE CERTIFICATE REQUIREMENTS

1. It is a condition of bid that the taxes of the successful bidder must be in order, or that satisfactory arrangements have been made with South African Revenue Service (SARS) to meet the bidder's tax obligations.
2. In order to meet this requirement bidders are required to complete in full the form TCC 001 "Application for a Tax Clearance Certificate" and submit it to any SARS branch office nationally. The Tax Clearance Certificate Requirements are also applicable to foreign bidders / individuals who wish to submit bids.
3. SARS will then furnish the bidder with a Tax Clearance Certificate that will be valid for a period of 1 (one) year from the date of approval.
4. The original Tax Clearance Certificate must be submitted together with the bid. Failure to submit the original and valid Tax Clearance Certificate will result in the invalidation of the bid. Certified copies of the Tax Clearance Certificate will not be acceptable.
5. In bids where Consortia / Joint Ventures / Sub-contractors are involved, each party must submit a separate Tax Clearance Certificate.
6. Copies of the TCC 001 "Application for a Tax Clearance Certificate" form are available from any SARS branch office nationally or on the website www.sars.gov.za.
7. Applications for the Tax Clearance Certificates may also be made via eFiling. In order to use this provision, taxpayers will need to register with SARS as eFilers through their website www.sars.gov.za



TSWELOPELE

LOCAL MUNICIPALITY
A MUNICIPALITY IN PROGRESS

MBD 4

DECLARATION OF INTEREST

1. Any legal person, including persons employed by the state¹, or persons having a kinship with persons employed by the state, including a blood relationship, may make an offer or offers in terms of this invitation to bid (includes an advertised competitive bid, a limited bid, a tender or written price quotation). In view of possible allegations of favouritism, should the resulting bid, or part thereof, be awarded to persons employed by the state, or to persons connected with or related to them, it is required that the bidder or his/her authorised representative declare his/her position in relation to the evaluating/adjudicating authority where-
 - a. the bidder is employed by the state; and/or
 - b. the legal person on whose behalf the bidding document is signed, has a relationship with persons/a person who are/is involved in the evaluation and or adjudication of the bid(s), or where it is known that such a relationship exists between the person or persons for or on whose behalf the declarant acts and persons who are involved with the evaluation and or adjudication of the bid.

2. In order to give effect to the above, the following questionnaire must be completed and submitted with the bid.

2.1. Full Name of bidder or his or her representative:

1.1. Identity Number:

1.2. Position occupied in the Company (director, trustee, shareholder², member):

1.3. Registration number of company, enterprise, close corporation, partnership agreement or trust:

1.4. Tax Reference Number:

Please initial here (witnesses included)

1.5. VAT

Registration

Number:

2.6.1 The names of all directors / trustees / shareholders / members, their individual identity numbers, tax reference numbers and, if applicable, employee / PERSAL numbers must be indicated in paragraph 3 below.

¹“State” means –

- (a) any national or provincial department, national or provincial public entity or constitutional institution within the meaning of the Public Finance Management Act, 1999 (Act No. 1 of 1999);
- (b) any municipality or municipal entity;
- (c) provincial legislature;
- (d) national Assembly or the national Council of provinces; or
- (e) Parliament.

²“Shareholder” means a person who owns shares in the company and is actively involved in the management of the enterprise or business and exercises control over the enterprise.

1.6. Are you or any person connected with the bidder presently employed by the state?

Page 150 of 177

Please initial here (witnesses included)

YES / NO

2.7.1 If so, furnish the following particulars:

Name of person / director / trustee / shareholder/ member:

Name of state institution at which you or the person connected to the bidder is employed:

Position occupied in the state institution:

Any other particulars:

Please initial here (witnesses included)

2.7.2 If you are presently employed by the state, did you obtain the appropriate authority to undertake remunerative work outside employment in the public sector?

YES / NO

2.7.2.1. If yes, did you attach proof of such authority to the bid document?

YES / NO

(NOTE: FAILURE TO SUBMIT PROOF OF SUCH AUTHORITY, WHERE APPLICABLE, MAY RESULT IN THE DISQUALIFICATION OF THE BID).

2.7.2.1 If no, furnish reasons for non-submission of such proof:

Please initial here (witnesses included)

2.8. Did you or your spouse, or any of the company's directors / trustees / shareholders / members or their spouses conduct business with the state in the previous twelve months?

YES / NO

2.8.1. If so, furnish particulars:

2.9. Do you, or any person connected with the bidder, have any relationship (family, friend, other) with a person employed by the state and who may be involved with the evaluation and or adjudication of this bid?

YES / NO

2.9.1 If so, furnish particulars.

Please initial here (witnesses included)

2.10. Are you, or any person connected with the bidder, aware of any relationship (family, friend, other) between any other bidder and any person employed by the state who may be involved with the evaluation and or adjudication of this bid?

YES / NO

2.10.1. If so, furnish particulars.

2.11. Do you or any of the directors / trustees / shareholders / members of the company have any interest in any other related companies whether or not they are bidding for this contract?

Please initial here (witnesses included)

YES / NO

2.11.1. If so, furnish particulars:

Please initial here (witnesses included)

2. FULL DETAILS OF DIRECTORS / TRUSTEES / MEMBERS / SHAREHOLDERS.

Full Name	Identity Number	Personal Income Tax Reference Number	State Number / Employee Peral Number

2. DECLARATION

I, THE UNDERSIGNED (NAME) _____

CERTIFY THAT THE INFORMATION FURNISHED IN PARAGRAPHS 2 and 3 ABOVE IS CORRECT and I ACCEPT THAT THE STATE MAY REJECT THE BID OR ACT AGAINST ME SHOULD THIS DECLARATION PROVE TO BE FALSE.

NAME OF THE BIDDER	
POSITION	
SIGNATURE	
DATE	



8. MUNICIPAL BIDDING DOCUMENT 6.1

MBD 6.1

PREFERENCE POINTS CLAIM FORM IN TERMS OF THE PREFERENTIAL PROCUREMENT REGULATIONS 2022

This preference form must form part of all tenders invited. It contains general information and serves as a claim form for preference points for specific goals.

NB: BEFORE COMPLETING THIS FORM, TENDERERS MUST STUDY THE GENERAL CONDITIONS, DEFINITIONS AND DIRECTIVES APPLICABLE IN RESPECT OF THE TENDER AND PREFERENTIAL PROCUREMENT REGULATIONS, 2022

1. GENERAL CONDITIONS

1.1 The following preference point systems are applicable to invitations to tender:

- the 80/20 system for requirements with a Rand value of up to R50 000 000 (all applicable taxes included); and
- the 90/10 system for requirements with a Rand value above R50 000 000 (all applicable taxes included).

1.2 **To be completed by the organ of state**

(delete whichever is not applicable for this tender).

- a) The applicable preference point system for this tender is the 90/10 preference point system.
- b) The applicable preference point system for this tender is the 80/20 preference point system.
- c) Either the 90/10 or 80/20 preference point system will be applicable in this tender. The lowest/ highest acceptable tender will be used to determine the accurate system once tenders are received.

1.3 Points for this tender (even in the case of a tender for income-generating contracts) shall be awarded for:

- (a) Price; and
- (b) Specific Goals.

1.4 **To be completed by the organ of state:**

The maximum points for this tender are allocated as follows:

	POINTS
PRICE	
SPECIFIC GOALS	
Total points for Price and SPECIFIC GOALS	100

1.5 Failure on the part of a tenderer to submit proof or documentation required in terms of this tender to claim points for specific goals with the tender, will be interpreted to mean that preference points for specific goals are not claimed.

1.6 The organ of state reserves the right to require of a tenderer, either before a tender is adjudicated or at any time subsequently, to substantiate any claim in regard to preferences, in any manner required by the organ of state.

2. DEFINITIONS

- (a) **“tender”** means a written offer in the form determined by an organ of state in response to an invitation to provide goods or services through price quotations, competitive tendering process or any other method envisaged in legislation;
- (b) **“price”** means an amount of money tendered for goods or services, and includes all applicable taxes less all unconditional discounts;
- (c) **“rand value”** means the total estimated value of a contract in Rand, calculated at the time of bid invitation, and includes all applicable taxes;
- (d) **“tender for income-generating contracts”** means a written offer in the form determined by an organ of state in response to an invitation for the origination of income-generating contracts through any method envisaged in legislation that will result in a legal agreement between the organ of state and a third party that produces revenue for the organ of state, and includes, but is not limited to, leasing and disposal of assets and concession contracts, excluding direct sales and disposal of assets through public auctions; and
- (e) **“the Act”** means the Preferential Procurement Policy Framework Act, 2000 (Act No. 5 of 2000).

3. FORMULAE FOR PROCUREMENT OF GOODS AND SERVICES

3.1. POINTS AWARDED FOR PRICE

3.1.1 THE 80/20 OR 90/10 PREFERENCE POINT SYSTEMS

A maximum of 80 or 90 points is allocated for price on the following basis:

$$\begin{array}{ccc}
 \mathbf{80/20} & \text{or} & \mathbf{90/10} \\
 \mathbf{Ps = 80} \left(\mathbf{1 - \frac{Pt - P_{min}}{P_{min}}} \right) & \text{or} & \mathbf{Ps = 90} \left(\mathbf{1 - \frac{Pt - P_{min}}{P_{min}}} \right)
 \end{array}$$

Where

- Ps = Points scored for price of tender under consideration
- Pt = Price of tender under consideration
- Pmin = Price of lowest acceptable tender

3.2. FORMULAE FOR DISPOSAL OR LEASING OF STATE ASSETS AND INCOME GENERATING PROCUREMENT

3.2.1. POINTS AWARDED FOR PRICE

A maximum of 80 or 90 points is allocated for price on the following basis:

$$\begin{array}{ccc}
 \mathbf{80/20} & \text{or} & \mathbf{90/10} \\
 \mathbf{Ps = 80} \left(\mathbf{1 + \frac{Pt - P_{max}}{P_{max}}} \right) & \text{or} & \mathbf{Ps = 90} \left(\mathbf{1 + \frac{Pt - P_{max}}{P_{max}}} \right)
 \end{array}$$

Where

- Ps = Points scored for price of tender under consideration
- Pt = Price of tender under consideration
- Pmax = Price of highest acceptable tender

4. POINTS AWARDED FOR SPECIFIC GOALS

- 4.1. In terms of Regulation 4(2); 5(2); 6(2) and 7(2) of the Preferential Procurement Regulations, preference points must be awarded for specific goals stated in the tender. For the purposes of this tender the tenderer will be allocated points based on the goals stated in table 1 below as may be supported by proof/ documentation stated in the conditions of this tender:
- 4.2. In cases where organs of state intend to use Regulation 3(2) of the Regulations, which states that, if it is unclear whether the 80/20 or 90/10 preference point system applies, an organ of state must, in the tender documents, stipulate in the case of—
 - (a) an invitation for tender for income-generating contracts, that either the 80/20 or 90/10 preference point system will apply and that the highest acceptable tender will be used to determine the applicable preference point system; or
 - (b) any other invitation for tender, that either the 80/20 or 90/10 preference point

system will apply and that the lowest acceptable tender will be used to determine the applicable preference point system, then the organ of state must indicate the points allocated for specific goals for both the 90/10 and 80/20 preference point system.

Table 1: Specific goals for the tender and points claimed are indicated per the table below.

(Note to organs of state: Where either the 90/10 or 80/20 preference point system is applicable, corresponding points must also be indicated as such.

Note to tenderers: The tenderer must indicate how they claim points for each preference point system.)

The specific goals allocated points in terms of this tender	Number of points allocated (90/10 system) (To be completed by the organ of state)	Number of points allocated (80/20 system) (To be completed by the organ of state)	Number of points claimed (90/10 system) (To be completed by the tenderer)	Number of points claimed (80/20 system) (To be completed by the tenderer)
Black owned				
Black Women				
Disabled Person				
Locality				
Total Points				

DECLARATION WITH REGARD TO COMPANY/FIRM

4.3. Name of company/firm.....

4.4. Company registration number:

4.5. TYPE OF COMPANY/ FIRM

- Partnership/Joint Venture / Consortium
- One-person business/sole propriety
- Close corporation
- Public Company
- Personal Liability Company
- (Pty) Limited
- Non-Profit Company
- State Owned Company

[TICK APPLICABLE BOX]

4.6. I, the undersigned, who is duly authorised to do so on behalf of the company/firm, certify that the points claimed, based on the specific goals as advised in the tender, qualifies the company/ firm for the preference(s) shown and I acknowledge that:

- i) The information furnished is true and correct;
- ii) The preference points claimed are in accordance with the General Conditions as indicated in paragraph 1 of this form;
- iii) In the event of a contract being awarded as a result of points claimed as shown in paragraphs 1.4 and 4.2, the contractor may be required to furnish documentary proof to the satisfaction of the organ of state that the claims are correct;
- iv) If the specific goals have been claimed or obtained on a fraudulent basis or any of the conditions of contract have not been fulfilled, the organ of state may, in addition to any other remedy it may have –
 - (a) disqualify the person from the tendering process;
 - (b) recover costs, losses or damages it has incurred or suffered as a result of that person's conduct;
 - (c) cancel the contract and claim any damages which it has suffered as a result of having to make less favourable arrangements due to such cancellation;
 - (d) recommend that the tenderer or contractor, its shareholders and directors, or only the shareholders and directors who acted on a fraudulent basis, be restricted from obtaining business from any organ of state for a period not exceeding 10 years, after the *audi alteram partem* (hear the other side) rule has been applied; and
 - (e) forward the matter for criminal prosecution, if deemed necessary.

<p>WITNESSES</p> <p>1.</p> <p>2.</p>	<p>.....</p> <p>SIGNATURE(S) OF BIDDERS(S)</p> <p>DATE:.....</p> <p>ADDRESS.....</p> <p>.....</p> <p>.....</p>
--	--

Points for the specific goals for contracting with persons, or categories of persons, historically disadvantaged by unfair discrimination on the basis of race:

Black-owned and B-BBEE Status Level of Contributor	Number of points on 80/20 points system	Number of points on 90/10 points system	Required Proof
100% Black-owned enterprise with a valid B-BBEE level 1	6	3	Sworn affidavit/BBBEE verification certificate (SANA) approved or from a registered accountant
51% Black-owned enterprise with a valid B-BBEE level 2	4	2	BBBEE Certificate from a SANAS approved agency
51% Black-owned enterprise with a valid B-BBEE level 3	2	1	BBBEE Certificate from a SANAS approved agency
Less than 51% Black-owned enterprise irrespective of B-BBEE level	0	0	BBBEE Certificate from a SANAS approved agency

Points for the specific goals for contracting with persons, or categories of persons, historically disadvantaged by unfair discrimination on the basis of gender:

Women-owned and B-BBEE Status Level of Contributor	Number of points on 80/20 points system	Number of points on 90/10 points system	Required Proof
100% Women-owned enterprise with no B-BBEE certificate	4	2	Sworn affidavit/BBBEE verification certificate (SANA) approved or from a registered accountant
51% Women-owned enterprise with a valid B-BBEE level 1	3	1	BBBEE Certificate from a SANAS approved agency
51% Women-owned enterprise with a valid B-BBEE level 2	2	1	BBBEE Certificate from a SANAS approved agency
51% Women-owned enterprise with a valid B-BBEE level 3	1	1	BBBEE Certificate from a SANAS approved agency
Less than 51% Women-owned enterprise irrespective of B-BBEE level	0	0	BBBEE Certificate from a SANAS approved agency

Points for the specific goals for contracting with persons, or categories of persons, historically disadvantaged by unfair discrimination on the basis of disability:

Black-owned and B-BBEE Status Level of Contributor	Number of points on 80/20 points system	Number of points on 90/10 points system	Required Proof
100% Disabled-owned enterprise with no B-BBEE certificate but with proof of disability.	4	2	Sworn affidavit and medical certificate
51% Disabled-owned enterprise with a valid B-BBEE level 1	3	1	BBBEE Certificate from a SANAS approved agency
51% Disabled-owned enterprise with a valid B-BBEE level 2	2	1	BBBEE Certificate from a SANAS approved agency
51% Disabled-owned enterprise with a valid B-BBEE level 3	1	1	BBBEE Certificate from a SANAS approved agency
Less than 51% Disabled-owned enterprise irrespective of B-BBEE level	0	0	BBBEE Certificate from a SANAS approved agency

Points for the specific goals for contracting with persons, or categories of persons, historically disadvantaged by unfair discrimination on the basis of Youth:

Black-owned and B-BBEE Status Level of Contributor	Number of points on 80/20 points system	Number of points on 90/10 points system	Required Proof
100% Youth-owned enterprise with no B-BBEE certificate but with proof of disability.	4	2	Sworn affidavit and medical certificate
51% Youth-owned enterprise with a valid B-BBEE level 1	3	1	BBBEE Certificate from a SANAS approved agency
51% Youth-owned enterprise with a valid B-BBEE level 2	2	1	BBBEE Certificate from a SANAS approved agency
51% Youth-owned enterprise with a valid B-BBEE level 3	1	1	BBBEE Certificate from a SANAS approved agency
Less than 51% Youth-owned enterprise irrespective of B-BBEE level	0	0	BBBEE Certificate from a SANAS approved agency



TSWELOPELE

LOCAL MUNICIPALITY
A MUNICIPALITY IN PROGRESS

9. MUNICIPAL BIDDING DOCUMENT 8

MBD 8

DECLARATION OF BIDDER'S PAST SUPPLY CHAIN MANAGEMENT PRACTICES

- 1 This Municipal Bidding Document must form part of all bids invited.
- 2 It serves as a declaration to be used by municipalities and municipal entities in ensuring that when goods and services are being procured, all reasonable steps are taken to combat the abuse of the supply chain management system.
- 3 The bid of any bidder may be rejected if that bidder, or any of its directors have:
 - a. abused the municipality's / municipal entity's supply chain management system or committed any improper conduct in relation to such system;
 - b. been convicted for fraud or corruption during the past five years;
 - c. willfully neglected, reneged on or failed to comply with any government, municipal or other public sector contract during the past five years; or
 - d. been listed in the Register for Tender Defaulters in terms of section 29 of the Prevention and Combating of Corrupt Activities Act (No 12 of 2004).
- 4 **In order to give effect to the above, the following questionnaire must be completed and submitted with the bid.**

ITEM	QUESTION	YES	NO
4.1	<p>Is the bidder or any of its directors listed on the National Treasury's database as a company or person prohibited from doing business with the public sector?</p> <p>(Companies or persons who are listed on this database were informed in writing of this restriction by the National Treasury after the <i>audi alteram partem</i> rule was applied).</p>	Yes <input type="checkbox"/>	No <input type="checkbox"/>
4.1.1	If so, furnish particulars:		
4.2	<p>Is the bidder or any of its directors listed on the Register for Tender Defaulters in terms of section 29 of the Prevention and Combating of Corrupt Activities Act (No 12 of 2004)?</p>	Yes <input type="checkbox"/>	No <input type="checkbox"/>
4.2.1	If so, furnish particulars:		

4.3	Was the bidder or any of its directors convicted by a court of law (including a court of law outside the Republic of South Africa) for fraud or corruption during the past five years?	Yes <input type="checkbox"/>	No <input type="checkbox"/>
4.3.1	If so, furnish particulars:		
4.4	Does the bidder or any of its directors owe any municipal rates and taxes or municipal charges to the municipality / municipal entity, or to any other municipality / municipal entity, that is in arrears for more than three months?	Yes <input type="checkbox"/>	No <input type="checkbox"/>
4.4.1	If so, furnish particulars:		

4.5	Was any contract between the bidder and the municipality / municipal entity or any other organ of state terminated during the past five years on account of failure to perform on or comply with the contract?	Yes <input type="checkbox"/>	No <input type="checkbox"/>
4.6.1	If so, furnish particulars:		

CERTIFICATION

I, THE UNDERSIGNED (FULL NAME)

CERTIFY THAT THE INFORMATION FURNISHED ON THIS DECLARATION FORM IS/ARE TRUE AND CORRECT.

I ACCEPT THAT, IN ADDITION TO CANCELLATION OF A CONTRACT, ACTION MAY BE TAKEN AGAINST ME SHOULD THIS DECLARATION PROVE TO BE FALSE.

NAME OF BIDDER	
POSITION	
SIGNATURE	
DATE	



TSWELOPELE

LOCAL MUNICIPALITY
A MUNICIPALITY IN PROGRESS

10. MUNICIPAL BIDDING DOCUMENT 9

MBD 9

CERTIFICATE OF INDEPENDENT BID DETERMINATION

1. This Municipal Bidding Document (MBD) must form part of all bids¹ (*1 Includes price quotations, advertised competitive bids, limited bids and proposals*) invited.
2. Section 4 (1) (b) (iii) of the Competition Act No. 89 of 1998, as amended, prohibits an agreement between, or concerted practice by, firms, or a decision by an association of firms, if it is between parties in a horizontal relationship and if it involves collusive bidding (or bid rigging).² Collusive bidding is a *pe se* prohibition meaning that it cannot be justified under any grounds (*2 Bid rigging (or collusive bidding) occurs when businesses, that would otherwise be expected to compete, secretly conspire to raise prices or lower the quality of goods and / or services for purchasers who wish to acquire goods and / or services through a bidding process. Bid rigging is, therefore, an agreement between competitors not to compete*).
3. Municipal Supply Regulation 38 (1) prescribes that a supply chain management policy must provide measures for the combating of abuse of the supply chain management system, and must enable the accounting officer, among others, to:
 - a. take all reasonable steps to prevent such abuse;

- b. reject the bid of any bidder if that bidder or any of its directors has abused the supply chain management system of the municipality or municipal entity or has committed any improper conduct in relation to such system; and
 - c. cancel a contract awarded to a person if the person committed any corrupt or fraudulent act during the bidding process or the execution of the contract.
4. This MBD serves as a certificate of declaration that would be used by institutions to ensure that, when bids are considered, reasonable steps are taken to prevent any form of bid-rigging.
 5. In order to give effect to the above, the attached Certificate of Bid Determination (MBD 9) must be completed and submitted with the bid:

CERTIFICATE OF INDEPENDENT BID DETERMINATION

I, the undersigned, in submitting the accompanying bid: “: – **SCM/TSW18/2023-2024: REPAIRS AND MAITENANCE OF SEWERAGE PUMPS WITHIN TSWELOPELE LOCAL MUNICIPALITY FOR THE PERIOD ENDING 30 JUNE 2026**”.

in response to the invitation for the bid made by Tswelopele Local Municipality do hereby make the following statements that I certify to be true and complete in every respect:

I certify, on behalf of _____ that:

(Name of Bidder)

- i. I have read and I understand the contents of this Certificate;

- ii. I understand that the accompanying bid will be disqualified if this Certificate is found not to be true and complete in every respect;
 - iii. I am authorized by the bidder to sign this Certificate, and to submit the accompanying bid, on behalf of the bidder;
 - iv. Each person whose signature appears on the accompanying bid has been authorized by the bidder to determine the terms of, and to sign, the bid, on behalf of the bidder;
 - v. For the purposes of this Certificate and the accompanying bid, I understand that the word "competitor" shall include any individual or organization, other than the bidder, whether or not affiliated with the bidder, who:
 - a) has been requested to submit a bid in response to this bid invitation;
 - b) could potentially submit a bid in response to this bid invitation, based on their qualifications, abilities or experience; and
 - c) provides the same goods and services as the bidder and/or is in the same line of business as the bidder
6. The bidder has arrived at the accompanying bid independently from, and without consultation, communication, agreement or arrangement with any competitor. However communication between partners in a joint venture or consortium³ (³ *Joint venture or Consortium means an association of persons for the purpose of combining their expertise, property, capital, efforts, skill and knowledge in an activity for the execution of a contract*) will not be construed as collusive bidding.

7. In particular, without limiting the generality of paragraphs 6 above, there has been no consultation, communication, agreement or arrangement with any competitor regarding:
- (a) prices;
 - (b) geographical area where product or service will be rendered (market allocation)
 - (c) methods, factors or formulas used to calculate prices;
 - (d) the intention or decision to submit or not to submit, a bid;
 - (e) the submission of a bid which does not meet the specifications and conditions of the bid; or
 - (f) Bidding with the intention not to win the bid.
8. In addition, there have been no consultations, communications, agreements or arrangements with any competitor regarding the quality, quantity, specifications and conditions or delivery particulars of the products or services to which this bid invitation relates.
9. The terms of the accompanying bid have not been, and will not be, disclosed by the bidder, directly or indirectly, to any competitor, prior to the date and time of the official bid opening or of the awarding of the contract.
10. I am aware that, in addition and without prejudice to any other remedy provided to combat any restrictive practices related to bids and contracts, bids that are suspicious will be reported to the Competition Commission for investigation and possible imposition of administrative penalties in terms of

section 59 of the Competition Act No 89 of 1998 and or may be reported to the National Prosecuting Authority (NPA) for criminal investigation and or may be restricted from conducting business with the public sector for a period not exceeding ten (10) years in terms of the Prevention and Combating of Corrupt Activities Act No 12 of 2004 or any other applicable legislation.

NAME OF BIDDER	
SIGNATURE	
POSITION	
DATE	

16. DECLARATION BY TENDERER

I / We acknowledge that I / we am / are fully acquainted with the contents of the conditions of tender of this tender document and that I / we accept the conditions in all respects.

I / We agree that the laws of the Republic of South Africa shall be applicable to the contract resulting from the acceptance of *my / our tender and that I / we elect *domicillium citandi et executandi* (physical address at which legal proceedings may be instituted) in the Republic at:

I / We accept full responsibility for the proper execution and fulfilment of all obligations and conditions devolving in me / us under this agreement as the principal liable for the due fulfilment of this contract.

I / We furthermore confirm I / we satisfied myself / ourselves as to the corrections and validity of my / our tender; that the price quoted cover all the work / items specified in the tender documents and that the price(s) cover all my / our obligations under a resulting contract and that I / we accept that any mistake(s) regarding price and calculations will be at my / our risk.

I / We furthermore confirm that my / our offer remains binding upon me / us and open for acceptance by the Purchases / Employer during the validity period indicated and calculated from the closing date of the bid.

SIGNATURE	
CAPACITY	
NAME (PRINT)	
NAME OF FIRM	
DATE	

